



CB16

HYDRAULIC PILING RIG
FOR DEEP FOUNDATION DRILLING



CB16

HYDRAULIC PILING RIG

The Casagrande CB16 is a versatile hydraulic piling rig designed for a wide range of foundation applications. It is suitable for drilling boreholes in rotary piling and Large Diameter Piling (LDP), for inserting and extracting casings, operating a casing oscillator, and executing piles with the continuous flight auger method (CFA) and CFA Rapid. The rig also supports displacement piles (DP), soil mixing operations, the KRC1 diaphragm wall configuration, and various other specialised arrangements.

Developed using cutting-edge technology, the CB16 is engineered to deliver reliable performance even in the most challenging working conditions. Its design focuses on efficiency, durability and cost-effectiveness, ensuring high productivity across all piling operations.



1800 mm
Max. drilling diameter



57 m
Max. drilling depth



169 kNm
Max. torque



209 kW
Diesel engine power



44 t
Operating weight

Maximum values vary according to the set-up.

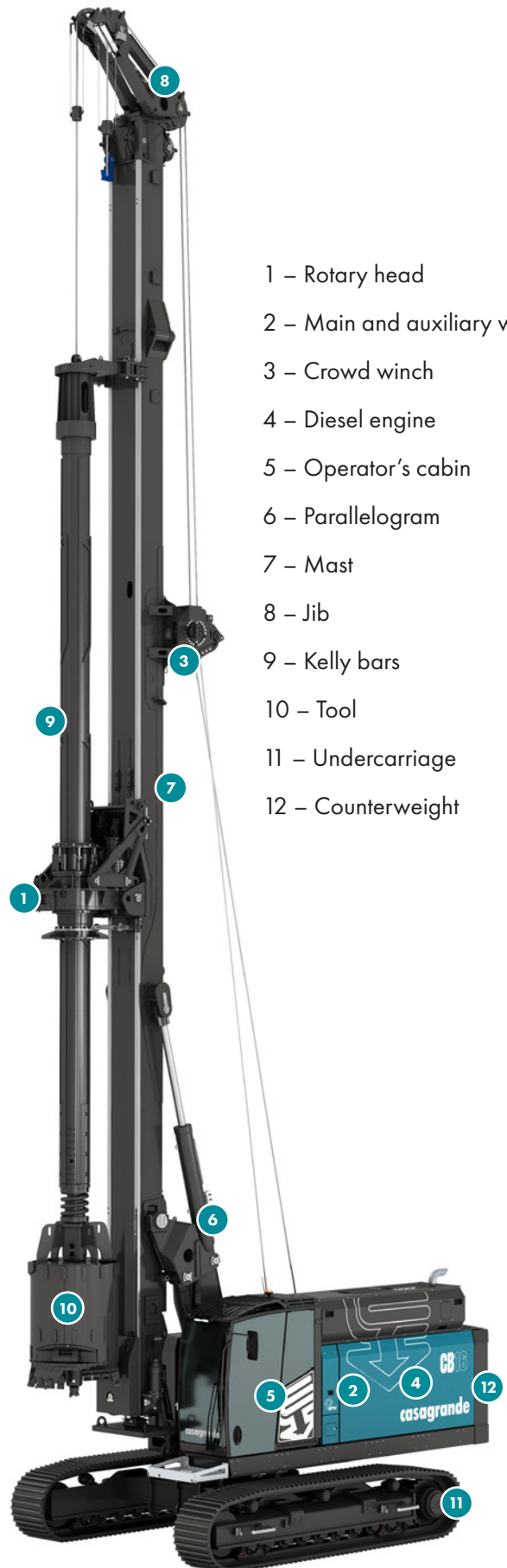

- 1 – Rotary head
- 2 – Main and auxiliary winch
- 3 – Crowd winch
- 4 – Diesel engine
- 5 – Operator's cabin
- 6 – Parallelogram
- 7 – Mast
- 8 – Jib
- 9 – Kelly bars
- 10 – Tool
- 11 – Undercarriage
- 12 – Counterweight

TECHNOLOGIES

BORED PILES

UNCASED

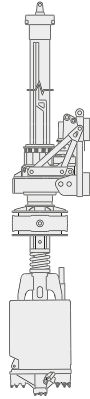

CASED

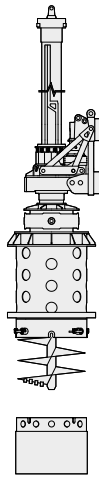

CASING OSCILLATOR

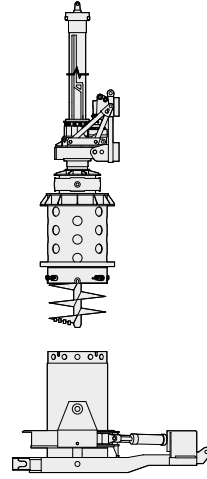

CROWD CYLINDER

Ø 1800 mm
Depth 57 m

Ø 1500 mm
Depth 57 m

Ø 1300 mm

CROWD WINCH

Ø 1500 mm
Depth 57 m

Ø 1180 mm
Depth 57 m

Ø 1180 mm

LONG STROKE

CFA

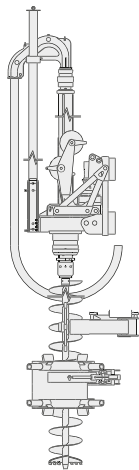

Ø 900 mm
Depth 25,5 m

CFA-R

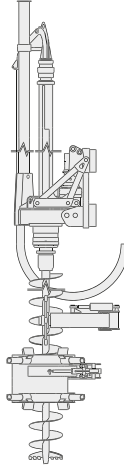

Ø 900 mm
Depth 23 m

DISPLACEMENT PILES

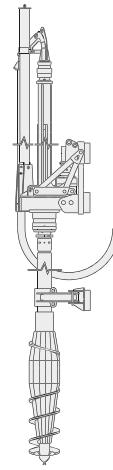

Ø 420 mm
Depth 22,5 m

SOIL MIXING

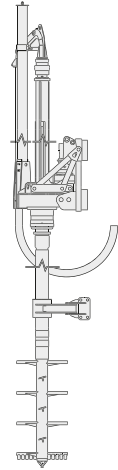

Ø 1000 mm
Depth 22,5 m

SPECIAL ARRANGEMENTS

KRC1

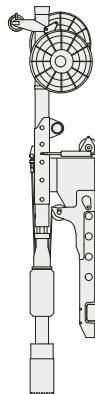

Depth 30 m
(K2500 x 800)

DTH HAMMER

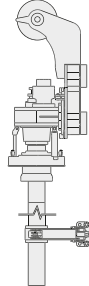

Stroke 15,5 m

JET GROUTING

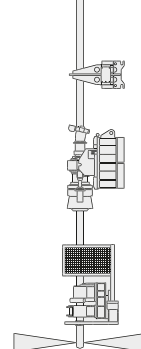

Depth 68 m

MICROPILING



Depth 16 m

KEYPOINTS



SPM - SMART POWER MANAGEMENT

The ability to intelligently manage engine power according to each specific function translates into greater efficiency and productivity. A dedicated system continuously detects the required power, increasing it to its maximum level only when necessary.



CFM - FLEET MASTER

The CFM system, developed and refined in collaboration with Vodafone, instantly detects any alarms or malfunctions through an online platform accessible from PCs, tablets, and smartphones. Thanks to the standard integration of Vodafone Business connectivity, real-time monitoring enables immediate intervention in case of failures, significantly reducing downtime and optimizing the rig productivity.



CDR - DATA RECORDER (OPTIONAL)

The CDR monitoring system of the drilling process, allows for the detection and recording of the working parameters. These data can be analyzed and processed to generate detailed jobsite reports.



ENVIRONMENT AWARENESS

The latest-generation Stage V diesel engines reduce pollutant emissions and allow operation with both lowsulfur fuels and HVO (Hydrotreated Vegetable Oil)—a high-performance, low CO₂ emission fuel taken from waste animal fats and used vegetable oils.



ERGONOMIC CABIN WITH HIGH VISIBILITY AND ACOUSTIC COMFORT

The cabin is designed to enhance operator comfort, reducing fatigue and increasing productivity while ensuring excellent visibility. It is also soundproofed to ensure optimal acoustic comfort and equipped with climate control system.



EASIER AND SAFER MAINTENANCE

The hydraulically lifting cover panels provide easy access to components for inspection and maintenance. Additionally, the optional platforms and safety railings further enhance operator safety during these tasks.



AUTOMATED DRILLING WITH REAL-TIME PROGRESS VERIFICATION

The automated drilling functions available on the rig, in addition to simplifying its operation, allow the operator to stay updated in real-time on the drilling process progress through an in-cabin display.



SIMPLIFIED AND CUSTOMIZED USABILITY

Each operator can create their preferred control system, avoiding potential operational errors and enhancing the safety of the operations.



REMOTE CONTROL (OPTIONAL)

The remote control, which allows to perfectly manage all rig movements, enhances the operator's safety during loading and unloading operations from transport vehicles and during the setup phases for work.



OPTIMAL OPERATION IN EXTREME ENVIRONMENTS (OPTIONAL)

The rig can be equipped with a kit that ensures optimal machine performance and maximum efficiency even in particularly cold environments. This includes hydraulic oil with stable viscosity and thermal properties, a hydraulic oil preheating device, and an enhanced climate control system for the cabin.





FEATURES

STANDARD EQUIPMENT

- SPM control system – Smart Power Management.
- 12" touch screen display for visualization and setting of drilling parameters 7" auxiliary display to manage diesel engine, cameras and auxiliary systems of the cabin.
- Mast lifting and lowering aid.
- Drilling depth measurement and automatic mast verticality control.
- Automatic idling mode with engine start/stop for fuel saving.
- Hook on auxiliary line.
- Protective roof guard (FOPS compliant).
- Air conditioning system.
- Front platform for service toolbox.
- Cabin platform.
- Electric refueling pump.
- Casagrande Fleet Master remote rig control and monitoring via internet.

OPTIONAL EQUIPMENT

BASE CARRIER

- Lateral platform and handrails.
- Handrails on upper structure.
- Water pre-heating system for starting engine at low - temperatures.
- Automatic centralized greasing system.
- Radio remote control for rigging, derigging, rig movement and positioning.
- Camera for panoramic view of the area around the rig.
- Automatic self-alignment of drilling axis.
- CDR - Casagrande Data Recorder.
- Transport kit according to required transport configuration.

ROTARY PILING

- Drilling axis extensions for larger diameter tools.
- Mast extensions for extended mast version.
- Cardanic joint for rotary head.
- Pull control and overload protection for crowd winch.
- Smart lowering and overload protection for main winch.
- Load cell an auxiliary winch for line pull monitoring.
- Arrangement for casing oscillator.
- Casing oscillator GCL 1300.

CFA

- Measurement and visualization of extraction and crowd force.
- Rotating cleaner hydraulically operated (CFA).
- Star cleaner (CFA).
- Lower guide with hydraulic opening.
- Hydraulic vibrator for cages.
- Feed control.
- Instrument for measuring, displaying and recording of drilling parameters. Complete with software for processing data on PC.
- Instrument for continuous extraction.

OPERATOR'S CABIN

The new Casagrande cabin offers a perfect balance of safety, comfort, and functionality, ensuring optimal working conditions for the operator in every situation.

Its wide glazed surfaces and optimized visibility provide a clear, unobstructed view of the drilling axis. The cabin comes equipped with a standard upper protective grid (FOPS compliant) and reinforced structure for maximum safety, while the front protective grid is available as an optional feature.

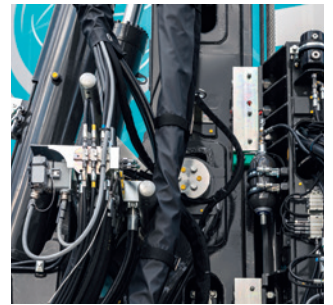

- **Excellent all-round visibility** — wide glazed surfaces and optimized lighting for maximum control and safety on site.
- **FOPS-certified protection grid** — ensures operator safety in every working condition.
- **High-efficiency air-conditioning system** — effective cooling and heating for optimal comfort in all climates.
- **Sound-insulated cabin** — reduced noise levels for greater concentration and operator well-being.
- **Ergonomic, adjustable and foldable seat** — designed for long working hours with superior comfort.
- **Simplified and customizable controls** — intuitive layout for quick operation and reduced fatigue.
- **Repositionable dual displays** — full customization and clear monitoring of machine functions.
- **Electric (CAN-bus) pedals** — precise, smooth response for accurate control.
- **Front and roof wipers** — clear visibility even in rain, mud, or low-light conditions.
- **USB ports and Bluetooth radio** — practical connectivity for modern work environments.

OPTIONAL FEATURES

ASSISTANCE SYSTEMS



12" Main display



7" Auxiliary display

AUTOMATIC IMPACT PROTECTION FOR THE KELLY BARS

An automatic control system slows down the rig main winch when the joints between the elements of the kelly bars meet. This ensures that the contact occurs at a reduced speed, preventing damage to the connection components.

INTERLOCKS IDENTIFICATION SYSTEM

The rig's display provides an accurate visualization of the kelly bar interlocks' position in relation to the rotary head. As a result, the operator can identify the correct interlock position, optimizing work time and reducing wear and damage to the kelly bar.

ADAPTIVE MACHINE CONTROL SYSTEM

A dedicated electronic system, available on all Casagrande machines, allows for adjusting the drill rig's response to the control activation speed, providing either a more immediate or relaxed operation depending on the operator's preferences and the type of excavation technology used.

AUTOMATIC DRILLING AND EXTRACTION CONTROL

In long stroke drilling systems (CFA, soil mixing, displacement), the advancement and extraction speeds of the tool can be automatically controlled, without the need for operator intervention. This optimizes concrete consumption and ensures the perfect execution of the pile, while simultaneously increasing the machine's productivity.

CPS – CASAGRANDE POSITIONING SYSTEM

The CPS satellite positioning system allows for locating the position of the pile to be drilled without the need for a ground-based visual reference. The precision is such that the system can be used in any condition, even in cases where physical staking cannot be followed.

TECHNICAL SPECIFICATIONS

BASE CARRIER

ENGINE		STAGE V-TIER 4	UN/ECE R96 *
Diesel engine model		CUMMINS B 6.7	CUMMINS QSB 6.7
Rated output @ 2000 rpm	kW	209	201
Diesel tank capacity	l	280	280
Urea tank capacity	l	57	-



Weight of base machine
without attachment

~25 t

*Exhaust emission equivalent Stage III A / Tier 3.

HYDRAULIC SYSTEM

Hydraulic power	kW	188
Hydraulic pressure	bar	350
Main pumps flow rate	l/min	3x214
Hydraulic oil tank capacity	l	360

UNDERCARRIAGE		STANDARD	OPTIONAL
Width of triple grouser track shoes	mm	600	800
Undercarriage width with retracted/extended tracks	mm	2500/3700	2850/3900
Overall tracks length	mm	4500	
Travel speed	km/h	0 ÷ 1,8	
Traction force-nominal/effective	kN	360/290	

WINCHES

MAIN WINCH

Line pull on 1st layer nominal/effective	kN	165/135
Max. line speed	m/min	87
Rope diameter	mm	24

AUXILIARY WINCH

Line pull on 1st layer nominal/effective	kN	73/60
Max. line speed	m/min	88
Rope diameter	mm	18

ROTARY HEAD

ROTARY HEAD R16.355

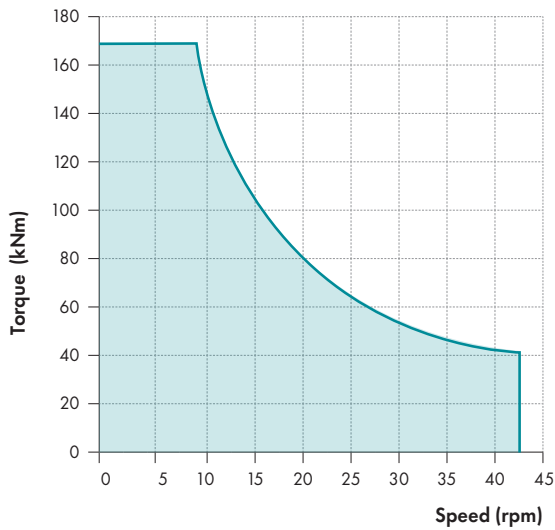

SPECIFICATIONS

Max. torque: 169 kNm
 Max. speed: 42 rpm
 Shaking system for tool discharge.

- N° 2 Hydraulic Motors with electronically controlled displacement and customizable parameters for the better exploitation of rotary performances.
- Inner passage for Kelly bars \varnothing 355 mm.
- Quick assembly and disassembly system of rotary head and slide using pins.
- Two assembly positions for easy and fast changing of drilling axle.

DRILLING AXIS

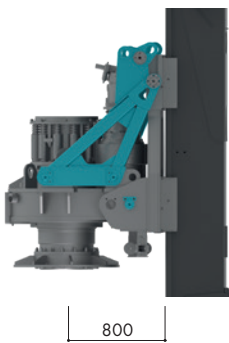

Standard

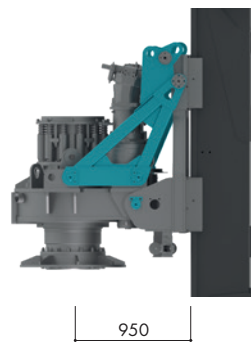

Extended

CARDANIC JOINT

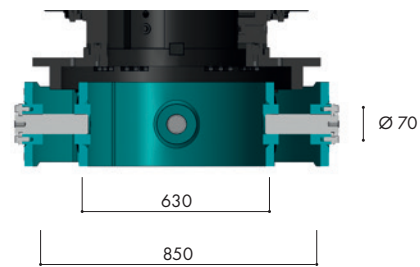

Type "C1"

CROWD CYLINDER

Extraction/Crowd force	kN	205/130
Extraction/Crowd speed	m/min	34/16
Stroke	m	5,2

CROWD WINCH

Extraction force nominal/effective	kN	343/274
Crowd force nominal/effective	kN	343/274
Extraction/Crowd speed	m/min	20
Extraction/Crowd fast speed	m/min	38
Rope diameter	mm	24
Max. Stroke	m	15,5

BORED PILING

CROWD CYLINDER ARRANGEMENT

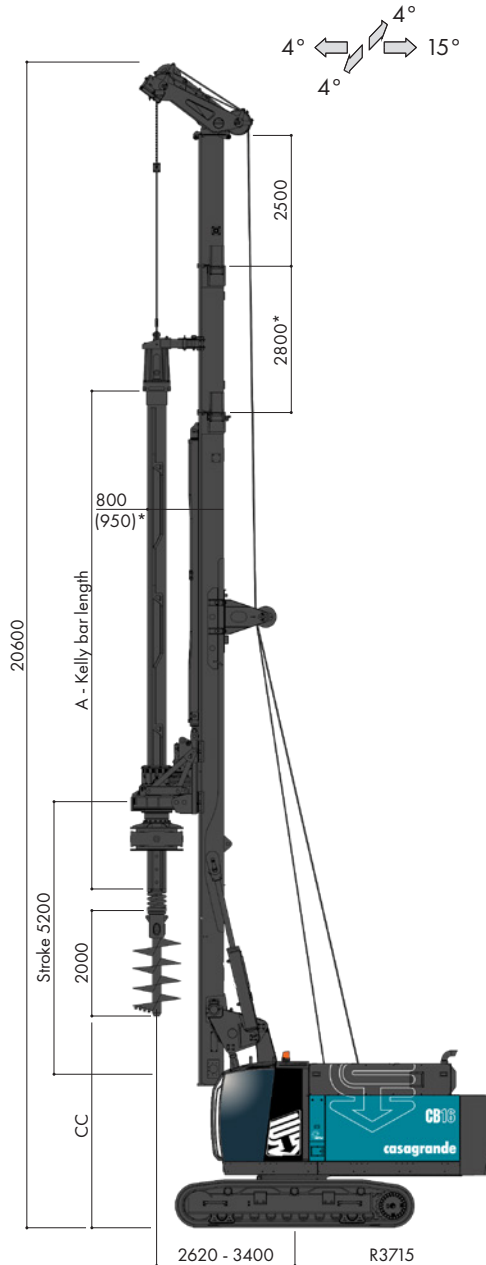

*Optional

CROWD WINCH ARRANGEMENT

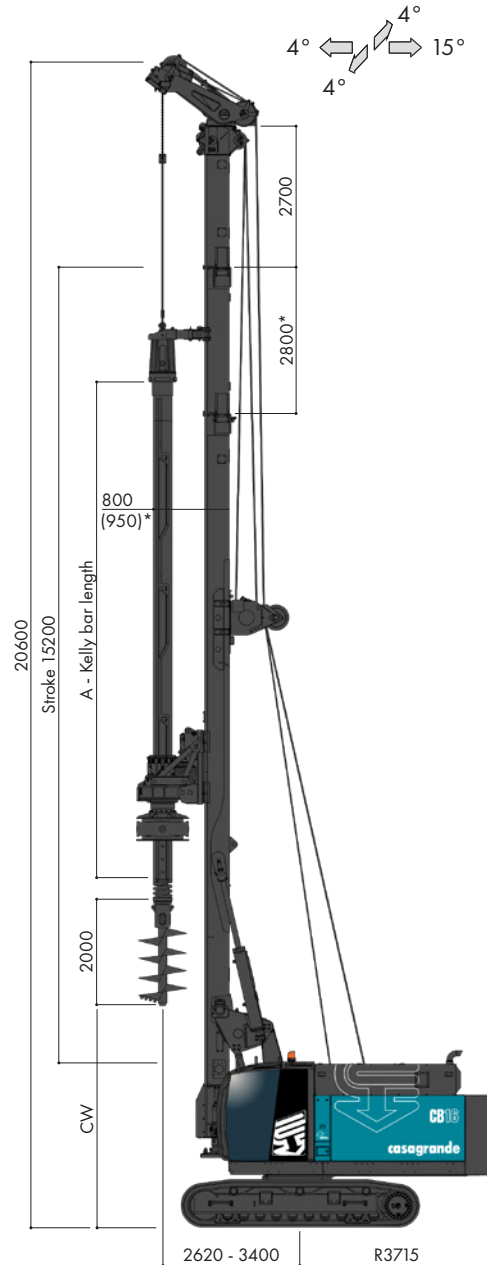

*Optional

DRILLING AXIS		CC 800	CC 950	CW 800	CW 950
Max. drilling diameter - uncased	mm	1500	1800	1200	1500
Max. drilling diameter - cased (Screw joints)	mm	1180	1500	880	1180
Operating weight with kelly bar 3x11000	t	44	44	46	46

KELLY BAR SPECIFICATIONS

Type					Nominal length (A)	CROWD CYLINDER		CROWD WINCH		Weight
Interlocking Friction	Nominal diameter	Number of element	Max. Torque	Kelly stub □		Drilling depth	Max. ground clearance (CR)	Drilling depth	Max. ground clearance (CW)	
type	mm	n°	kNm	mm	mm	m	m	m	m	kg
I	355	3	260	200	7500	19,2	8,4	19,1	9,0	3510
					9500	25,2	6,8	25,1	7,0	4310
					11000	29,7	5,3	29,6	5,5	4910
					12500	34,2	3,8	34,1	4,0	5500
I - F	355	4	220	200	7500	25,7	8,4	25,6	9,0	3650
					9500	33,7	6,8	33,6	7,0	4490
					11000	39,7	5,3	39,6	5,5	5110
					12500	45,7	3,8	45,6	4,0	5730
F	355	5	105	200	7500	32,2	8,4	32,1	9,0	3660
					9500	42,2	6,8	42,1	7,0	4500
					11000	49,7	5,3	49,6	5,5	5260
					12500	57,2	3,8	57,1	4,0	5760

ARRANGEMENT WITH CASING OSCILLATOR

CROWD CYLINDER ARRANGEMENT

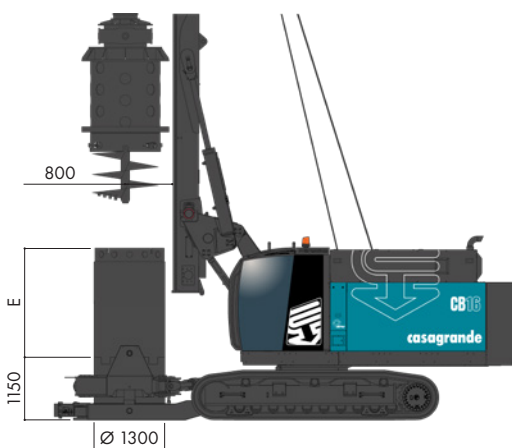

CROWD WINCH ARRANGEMENT

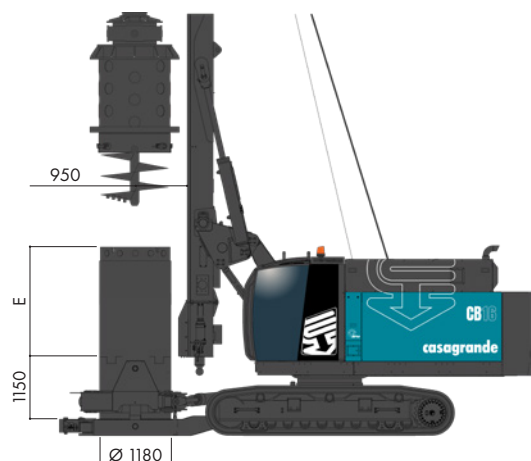

KELLY BAR LENGTH (A)	7500	9500	11000	12500
Nominal casing length (E) mm	3000	3000	3000	1000
Length of casing without oscillator mm	4000	4000	4000	3000

KELLY BAR LENGTH (A)	7500	9500	11000	12500
Nominal casing length (E) mm	7000	5000	3000	2000
Length of casing without oscillator mm	8000	6000	4000	3000

Data refer to depicted arrangement with 2800 optional mast extension.

BORED PILING

LOW HEADROOM

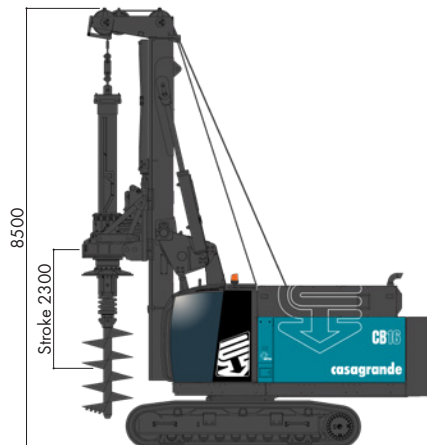

DRILLING DATA		LH
Max. drilling diameter	mm	1500
Max. drilling depth	m	15,2

UNDERMAST

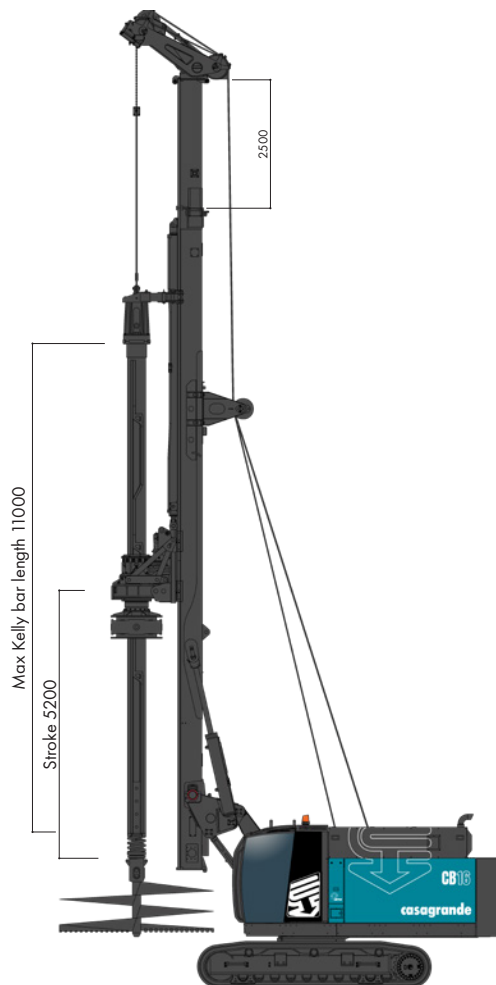

DRILLING DATA		UNDERMAST
Max. drilling diameter	mm	3000
Max. drilling depth	m	50



CFA PILING

CFA-R ARRANGEMENT

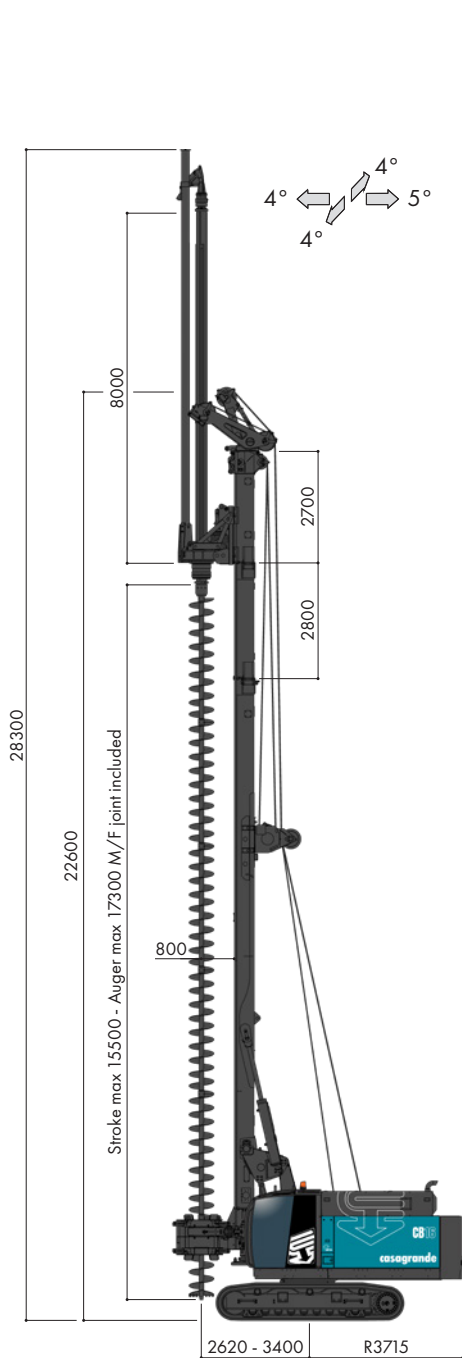

CFA ARRANGEMENT

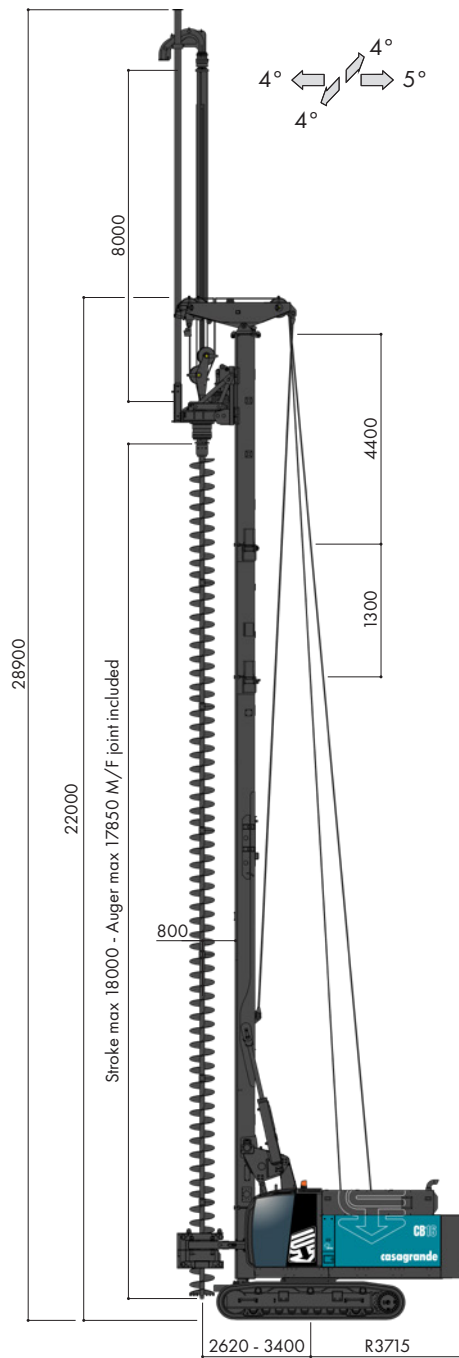

DRILLING DATA		CFA-R	CFA
Max. diameter	mm	900	900
Max. depth	m	23	25,5
Max. depth with rotating auger cleaner	m	20,4	24,3
Extraction force nominal/effective	kN	343/274	560/450
Extraction force (with additional pulls) nominal/effective	kN	500/400	-
Crowd force nominal/effective	kN	343/274	106/86*
Weight w/o auger (approx.)	t	45	44

*Depth reduced by 0,8 m with crowd force option.

Data refer to depicted arrangement.

CFA PILING

CONCRETE SWIVEL

Max. pressure: 50 bar
Max. speed: 50 rpm



MALE JOINT

Max. allowable torque: 220 kNm



MAX. 8-METER KELLY EXTENSION



SHORT DRIVE SLEEVE

WHEEL WITH ROPE INSERTS

TYPE	AUGER DIAMETER
A	350
B	400
B	450
C	500
C	600
C	800

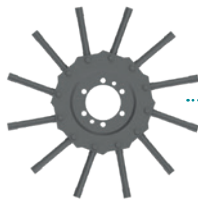

ROTATING AUGER CLEANER
Available for CFA min. \varnothing 400 mm

RIGID WHEEL

TYPE	AUGER DIAMETER
A	500
B	600
C	700
C	800
C	900

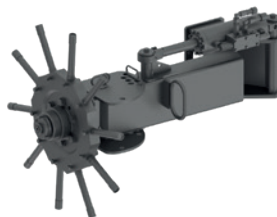

STAR TYPE AUGER CLEANER



DISPLACEMENT PILES & SOIL MIXING

DISPLACEMENT PILES ARRANGEMENT

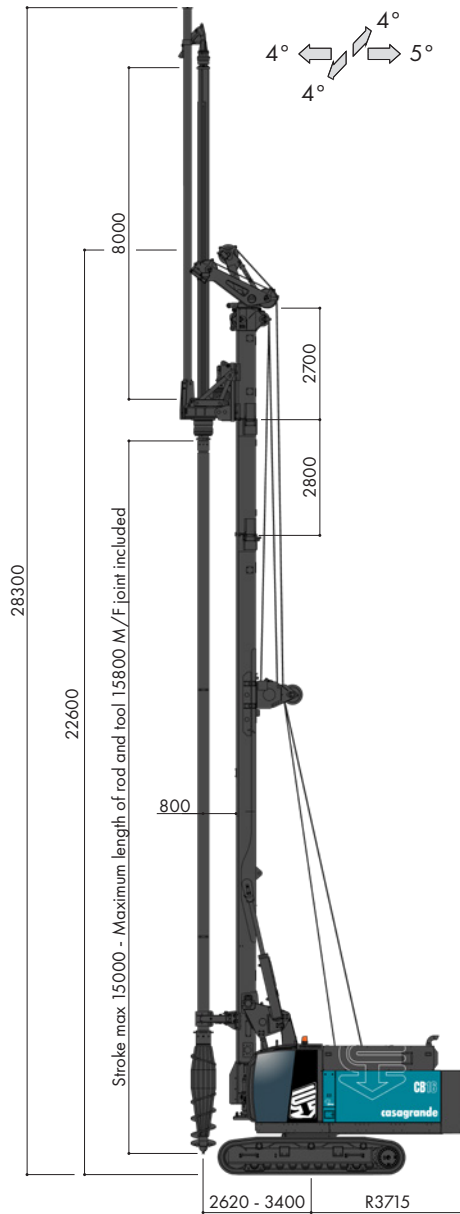

SOIL MIXING ARRANGEMENT

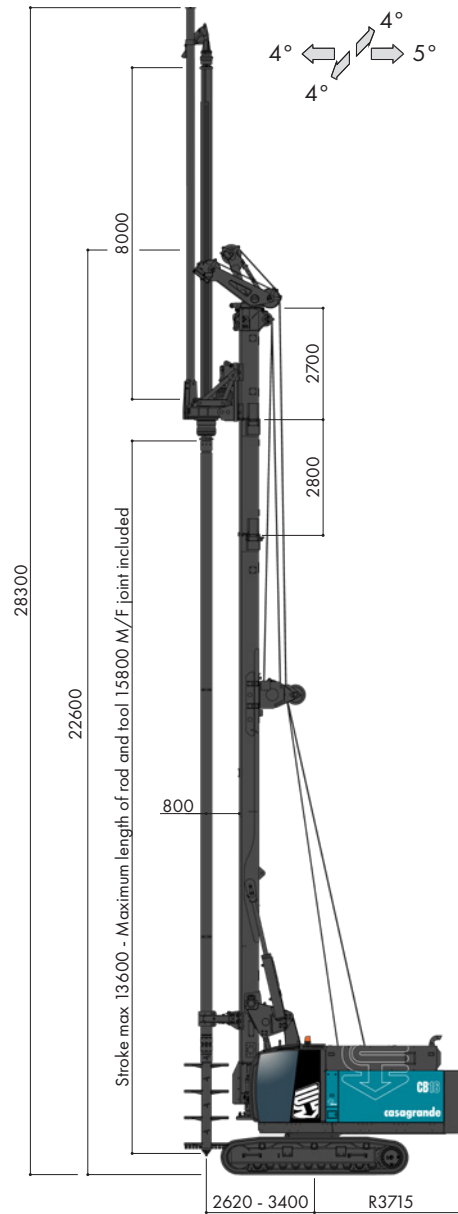

DRILLING DATA		DISPLACEMENT PILES	SOIL MIXING
Max. diameter	mm	420	1000
Max. depth	m	21,6	21,1
Extraction force nominal/effective	kN	343/274	343/274
Extraction force (with additional pulls) nominal/effective	kN	500/400	670/536
Crowd force nominal/effective	kN	343/274	343/274
Weight w/o tool (approx.)	t	45	45

KRC1 DIAPHRAGM WALL

KELLY KRC1 ARRANGEMENT

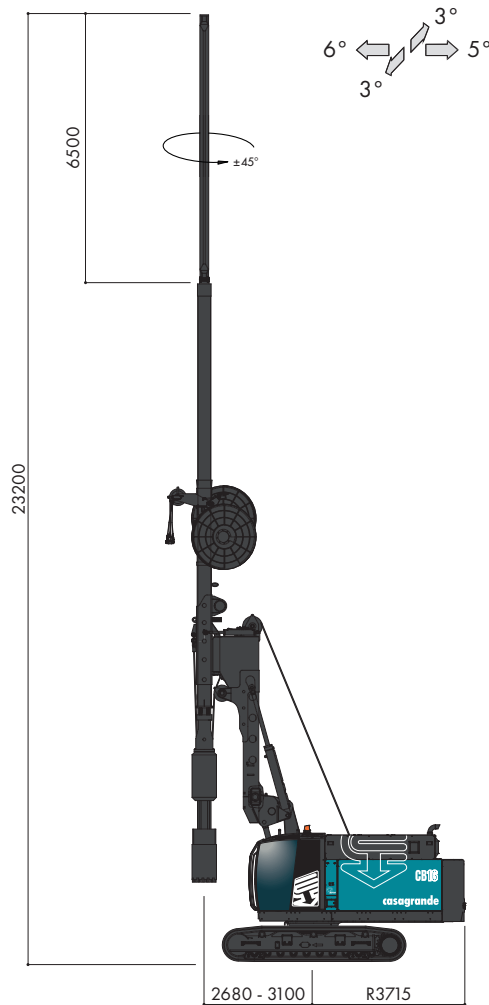

EXCAVATION DATA		K2200 HYDRAULIC GRAB	K2500 HYDRAULIC GRAB
Max. diaphragm width	mm	600	800
Max. depth with extension (6,5)	m	29,5	30
Auxiliary jib height	m	11,4	11,4
Extraction force nominal/effective	kN	335/270	335/270
Nominal/effective auxiliary winch rope pull	kN	73/60	73/60
Weight w/o grab (approx.)	t	37	37

TRANSPORT DATA

CROWD WINCH ARRANGEMENT

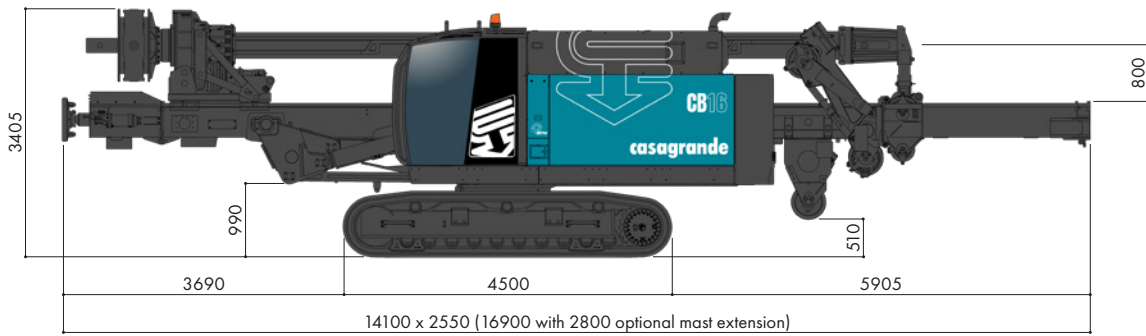

Weight of equipment in transport: 43300 kg (with 3x7500 friction kelly bars, kelly bars guide). Max. kelly length 9500 for on board transport.

CFA-R ARRANGEMENT

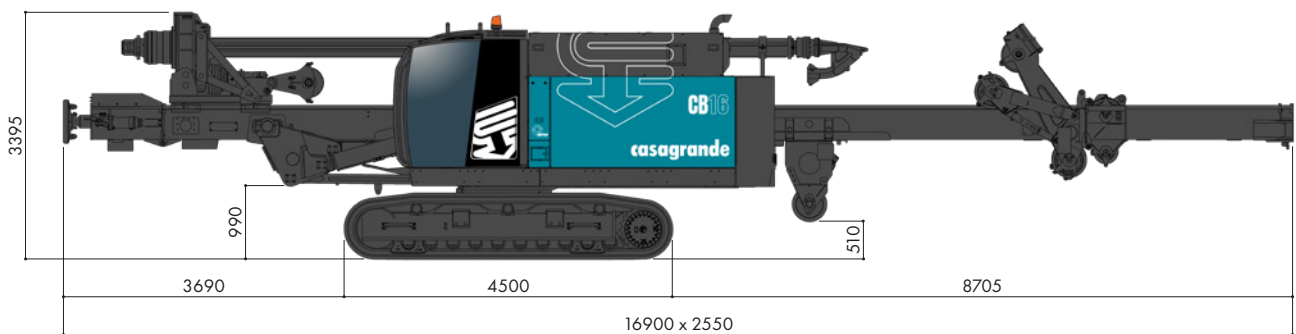

Weight of equipment in transport: 43650 kg (with 8 m CFA kelly extension, swan neck for concrete pipes).

CFA ARRANGEMENT

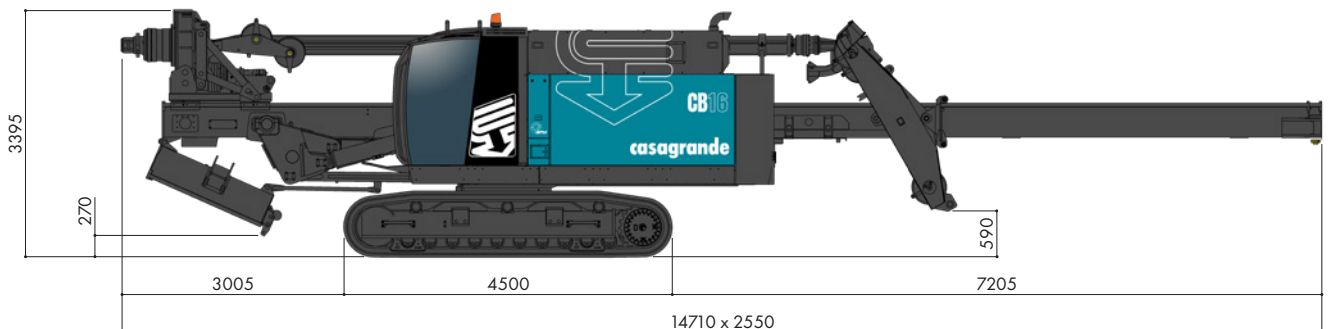

Weight of equipment in transport: 43000 kg (with 8 m CFA kelly extension, swan neck for concrete pipes).

KRC1 ARRANGEMENT

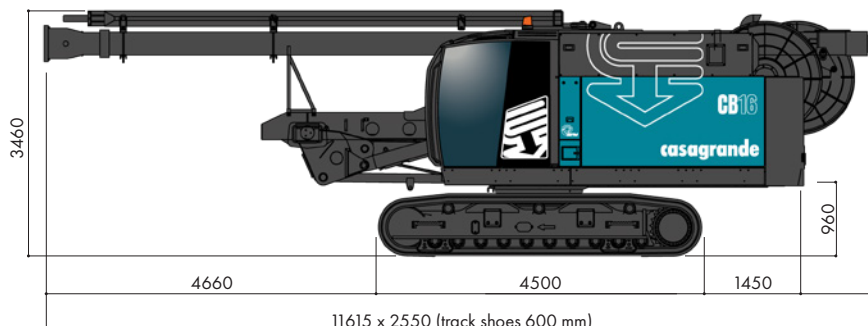

Mass of equipment in transport: 37000 kg. Max. kelly extension length 6500 for on board transport.



PREMIUM SUPPORT & WARRANTY PACKAGE



SMARTCARE

SMARTCARE - CASAGRANDE PREMIUM SUPPORT AND WARRANTY PACKAGE

Choosing Casagrande means investing in a machine designed for durability, precision, and maximum performance in special foundation works.

To preserve these values over time, SMARTCARE provides complete support throughout the entire lifecycle of your equipment — ensuring efficiency, reliability, and peace of mind.

SMARTCARE is offered as a separate package; availability and details may vary according to our sales conditions.

- **3-YEAR WARRANTY**

Up to 3 years or 4,500 operating hours of coverage to protect your investment and guarantee long-term reliability. Casagrande stands by your side even after delivery, ensuring lasting performance and operational confidence.

- **TECHNICAL ASSISTANCE & ORIGINAL SPARE PARTS**

Casagrande ensures on-site service with qualified technicians and genuine components specifically designed for your machine.

Each intervention extends equipment life, maintains optimal performance, and ensures operational continuity on every jobsite.

- **SMART SUPPORT**

Through advanced monitoring systems, Casagrande anticipates maintenance needs and recommends spare parts in advance.

This proactive approach reduces downtime and keeps your rig operating at maximum efficiency.

OFFICIAL SPARE PARTS — PLANNED IN ADVANCE

Prearranged original spare parts kits are available for each scheduled maintenance phase:

- Ready-to-install solutions ensuring full compatibility
- Simplified logistics and optimized stock management
- Extended component life and minimized downtime

ON-SITE TECHNICIAN EVERY 250 HOURS

Every 250 operating hours, a certified Casagrande technician can perform:

- Preventive inspections and complete check-ups
- Routine maintenance and necessary adjustments
- On-site operator guidance and technical support

DEDICATED TEAM — MONITORING & SUPPORT

The SMARTCARE Team continuously monitors machine hours and performance via Casagrande Fleet Master.

This system enables:

- Scheduled service interventions
- Early identification of spare parts needs
- Optimized maintenance planning and reduced downtime





CASAGRANDE S.P.A.

Via A. Malignani, 1
33074 Fontanafredda – Pordenone (Italy)
Tel. +39 0434 9941
info@casagrandegroup.com

SMARTCARE OFFICE

Tel. +39 0434 994377
smartcare@casagrandegroup.com

AFTER SALES SERVICE

Tel. +39 0434 994345
service@casagrandegroup.com



TECHNICAL ASSISTANCE



TRAINING COURSES



REMOTE ASSISTANT SERVICE



SERVICE BOXES



OFFICIAL SPARE PARTS