

MARINI

QUARRIES GROUP

MR - C 50



PERFORATRICE IDRAULICA
HYDRAULIC DRILLING RIG
FOREUSE HYDRAULIQUE
HYDRAULISCHE BOHRMASCHINE

MR
NEW ERA OF DRILLING MACHINES

MR - C Line

IT

MR- C 50 è una piccola macchina da perforazione cingolata con centrale idraulica separabile, ottimizzata per tutti i lavori di ingegneria civile, carotaggi, micropali, ancoraggi e consolidamenti. Adatta al lavoro in spazi stretti e di difficile accesso, è dotata di una centrale idraulica particolarmente potente in grado di erogare 115 HP per azionare ogni tipo di perforatrice idraulica o martello fondo foro ed eseguire ogni tipo di perforazione.

ENG

MR- C 50 is a small mobile drilling unit on tracks with separate hydraulic power pack, optimized for all the works of civil engineering, core drilling, micro piles, anchors and consolidations. Suitable to work in narrow spaces and difficult to access, it is equipped with a particularly powerful hydraulic station able to provide 115 HP, to operate any kind of hydraulic rock-drill or down-the-hole hammer and perform any type of drilling job.

DE

MR- C 50 ist eine sehr kompakte Bohrraube für Einsätze im Spezialtiefbau. Arbeiten wie Kernloch-, Überlagerungs-, Anker- und Mikropfahlbohrungen bis Durchmesser 300mm sind in engsten Platzverhältnissen möglich. Die enorme Flexibilität und Beweglichkeit ermöglicht hierbei nahezu jede erdenkliche Bohrposition. Das separat abkoppelbare Kraftpaket wird durch einen modernen, emissionsarmen Deutz Diesel mit 85 kW angetrieben.

FR

MR- C 50 est une petite unité de forage mobile sur les pistes avec bloc d'alimentation hydraulique séparé, optimisé pour tous les travaux de génie civil, carottage, micropieux, ancrages et consolidations. Convient pour travailler dans des espaces étroits et difficiles d'accès, il est équipé d'une station hydraulique particulièrement puissante capable de fournir 115 HP, pour faire fonctionner tout type de roche-foreuse hydraulique ou marteau fond de trou et d'effectuer tout type de travail de forage.

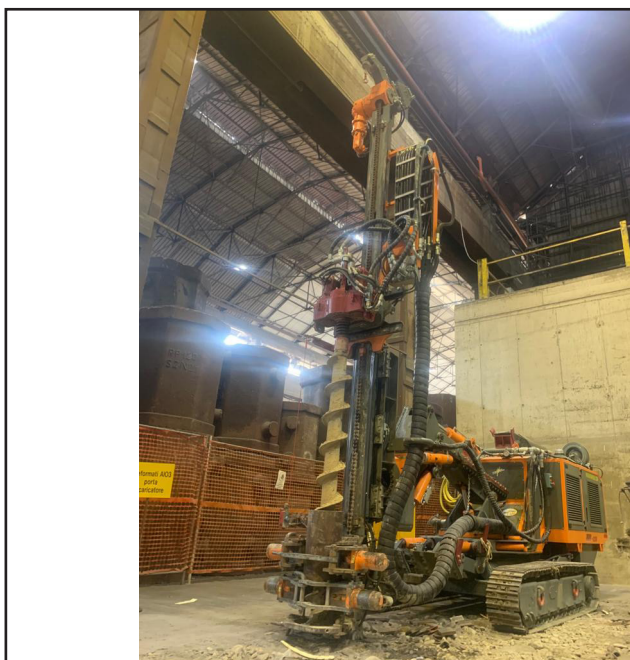

MR - C 50



Dati Tecnici- Technical Data- Caractéristiques Technique- Technische Daten

Carro Cingolato Undercarriage	Chariot chenille Fahrwerk			
Passo cingolo Wheel base	Enpattement Fahrwerk	1700 mm (5.57 ft)		
Careggiata variabile Variable track	Standbreite verstellbar Voie variable	1300 mm - 1800 mm (4.26- 5.90 ft)		
Larghezza suole Pad width	Langeur patins Fussbreite	300 mm (0.98 ft)		
Pendenza max. Max. climbing ability	Pente max. Steigfähigkeit max.	80%		
Velocità max. Max. speed	Vitesse max. Fahrgeschwindigkeit	2 Km/h (1.24 mph)		
Centrale idraulica Power Pack	Groupe Hydraulique Hydraulikaggregat			
Motore Diesel Diesel Engine	Moteur diesel Dieselmotor	Deutz TCD 3.6 L4	John Deere 4045HFC04	
Potenza motore Engine Power	Puissance moteur Antriebsleistung	85kW (115 Hp) @2200 rpm	97kW (130 Hp) @2200 rpm	
Pompa principale Main pump	Pompe principale Hydraulische Leistung	250 lpm @ 250 bar (66.1 gal/min @3626 psi)		
Serbatoio olio Oil tank	Réservoir huile Oiltank	300 Litri (79.25 gal)		
Serbatoio Gasolio Fuel Tank	Réservoir diesel Diesel tank	80 Litri (21.13 gal)		
Consumo carburante Fuel consumption	Consommation de carburant Kraftstoffverbrauch	6 l/h (1.58 gal/h)		
Raffreddamento Cooling	Kühlung Refroidissement	Scambiatore aria olio separato - Separate oil air exchanger Luftaustauscher / Ölabscheider / échangeur		
Mast Mast	Mat Lafette	CID 300		
Corsa utile (Modulare) Feed stroke (Modular)	Course utile (Modulaire) Vorschub (Modularer)	2500 mm (*) / 8.20 ft (*) - 3500 mm (*) / 11.48 ft (*)		
Lunghezza totale Total length	Longueur totale Gesamtlänge	4725 mm (*) / 15.5 ft (*) - 5725 mm (*) / 18.7 ft (*)		
Forza di spinta Feed force	Poussée Vorschubkraft	5000 daN / 11240 lbf		
Forza di tiro Retract force	Traction Rückzugskraft	5000 daN / 11240 lbf		
Teste di rotazione Rotary head	Tête de rotation Drehkopf	ID 800	HR 40	
Coppia max. Max. torque	Couple max. Drehmoment max.	330/660 daNm (2434/4868 lbft)	500/1000 daNm (3688/7376 lbft)	1360 daNm (1003 lbft)
Giri max. Max. speed	Vitesse max. Drehzahl max.	140/70 rpm	90/45 rpm	145 rpm
Marce Gears	Vitesses Gänge	2		4
Passaggio testa Head passage	Passege de la tête Drehkopfdurchgang	1 ½"		2"
Perforatore Rock drill	Perforateur Bohrer	MA 500 / 2 ID		
Coppia max. Max. torque	Couple max. Drehmoment max.	500/250 daNm(3688/1844 lbft) con motore/ with motor 250cc		
Giri max. Max. speed	Vitesse max. Drehzahl max.	40/80 rpm		
Forza di battuta Impact energy	Force de frappe Einzelschlagenergie	320 Nm		
Frequenza di battuta Impact frequency	Fréquence de frappe Schlagfrequenz	2100-2300 cpm		
Aste filettate ed auto perforanti Threaded and self-anchoring rods	Barres filetées et autoforeuses Gewindestangen und Bohr- schrauben	R32/R38/R51/ ISCHEBECK TITAN 30/40/52 / C90-R51		
(*) dimensioni variabili su richiesta / dimension variable on request/ dimensions variables sur demande/ variable abmessungen auf anfrage				

MR - C 50

Opzioni ed Accessori- Options and Accessories- Options et Accessoires- Optionen und Zubehör

Morse Clamps	Mors Klemm-und Brechvorrichtung	Mod: 70/230	Mod: 70/310
Diametro min. / max presa Clamping range	Tige diamètre min. / max Durchmesser min. / max	Ø 25 / 230 mm (0.98 / 9 in)	Ø 70 / 310 mm (2.74 / 12.20 in)
Forza di chiusura Clamping force	Force de serrage Klemmkraft	18000 daN @220 bar (40465 lb @ 3191 psi)	
Coppia svitaggio Breaking torque	Couple de deserrage Brechmoment	4000 daNm / 28933 lb ft	
Argano idraulico Hydraulic winch	Treuil hydraulique Hydraulische Seilwinde	Mod: 500	Mod: 1000
Tiro max. Max. pull	Max. Zugkraft Traction max.	500 daN / 1100 lb	1000 daN / 2200 lb
Lunghezza fune Rope length	Seillänge Longueur du câble	20 mt. (*) / 66 ft (*)	30 mt. (*) / 100 ft (*)
Diametro filo Rope diameter	Seildurchmesser Diamètre du fil	6 mm / 0.23 in	8 mm / 0.31 in
Centrale idraulica separabile Removable Power Pack	Groupe Hydraulique amovible Trennbare Hydraulikaggregat		
Max. distanza Max. distance	Max. distance Max. entfernung	35 mt. (*) / 115 ft (*)	
Pompa Acqua Water pump	Pompe à eau Wasserpumpe		
Pressione esercizio Working pressure	Pression de travail Arbeitsdruck	35 - 45 bar (507- 653 psi)	
Portata Flow	Flux Fließen	200 lpm (52.8 gal/min)	
Pompa schiumogeno Foam pump	Pompe à mousse Schaumpumpe		
Pressione esercizio Working pressure	Pression de travail Arbeitsdruck	150 bar (2176 psi)	
Portata Flow	Flux Fließen	30 lpm (7.93 gal/min)	
Carrello Apribile Openable cart	Chariot ouvrable Öffnungskorb	Mod: C A	
Corsa utile Feed stroke	Course utile Vorschub	490 mm (1.63 ft)	
Gabbia di protezione Protection cage	Cage de protection Schutzkäfig	Mod: M	Mod: R
Apertura opening	Ouverture Öffnung	Manuale /Manual Manuelle/Manuelle	Radiocomandata /Radio-controlled Radio-pilotée /Funkgesteuerte

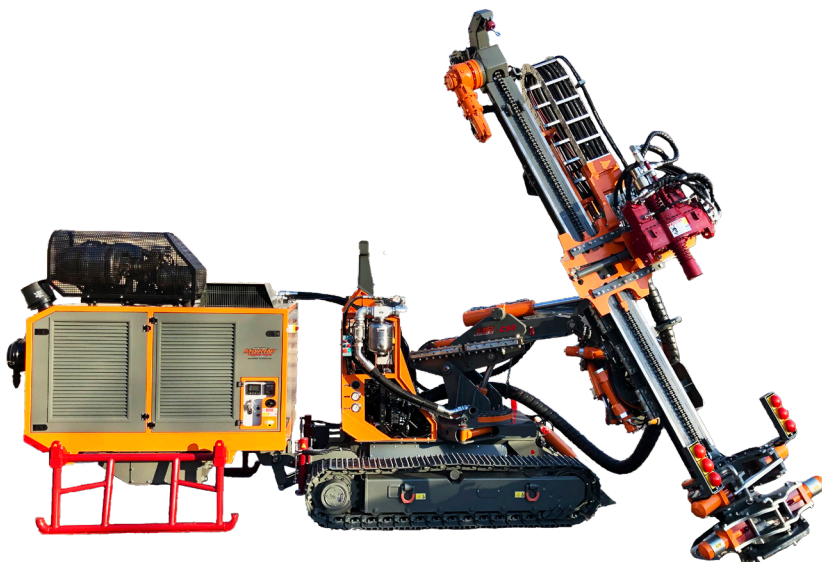

MR - C 50

Mast modulare (mm)- Modular mast (mm)- Mat modulaire (mm)- Lafette modularer (mm)

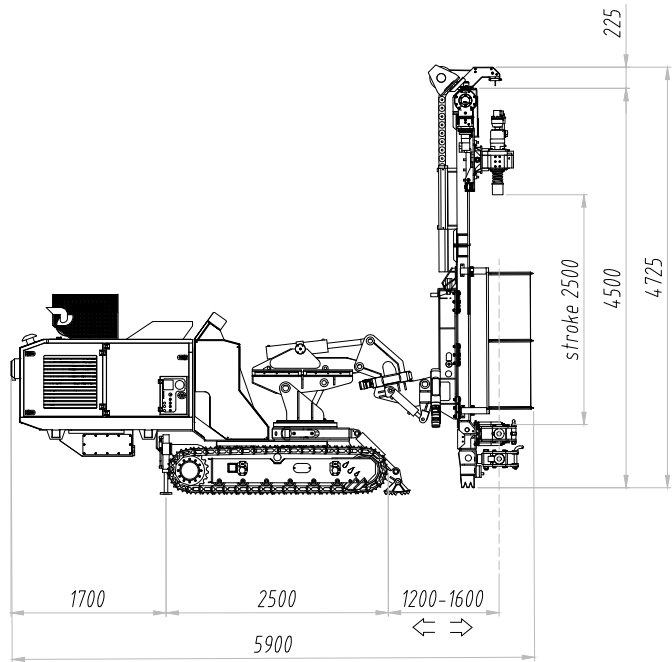
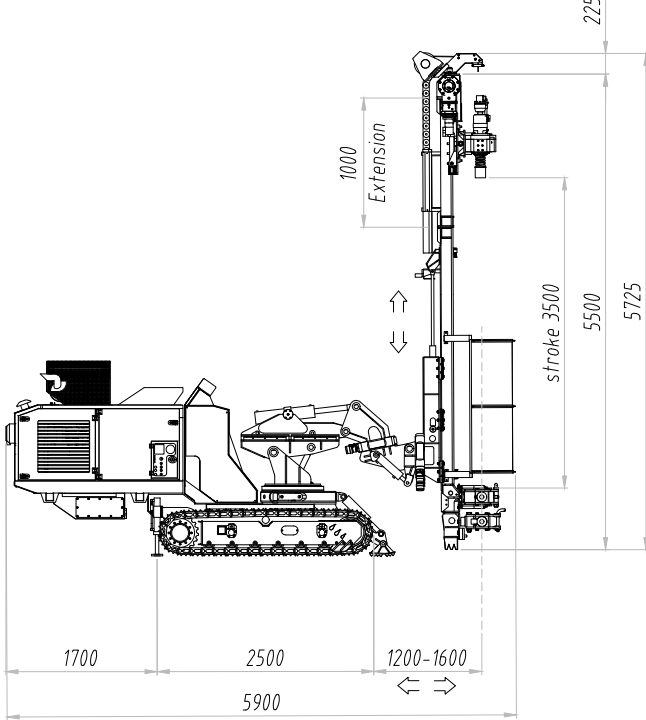

Movimenti Mast (mm)- Mast Movements (mm)- Cinématique du Bras (mm)- Volle Gelenkmöglichkeit (mm)

Perforazione in orizzontale e area di lavoro / horizontal drilling - working area
forage horizontal et zone de travail / horizontalbohrung und arbeitsbereich

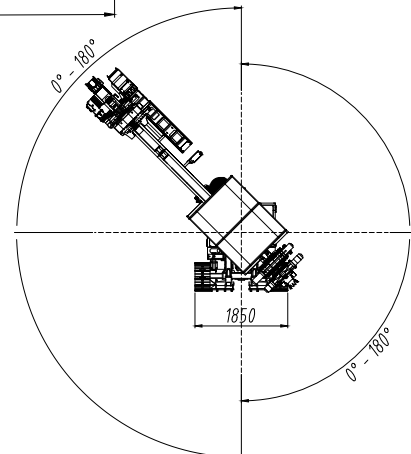
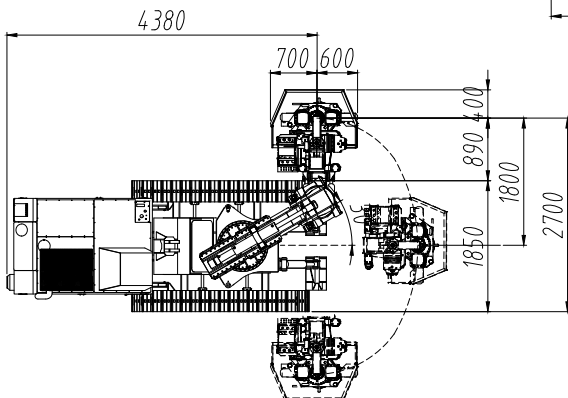
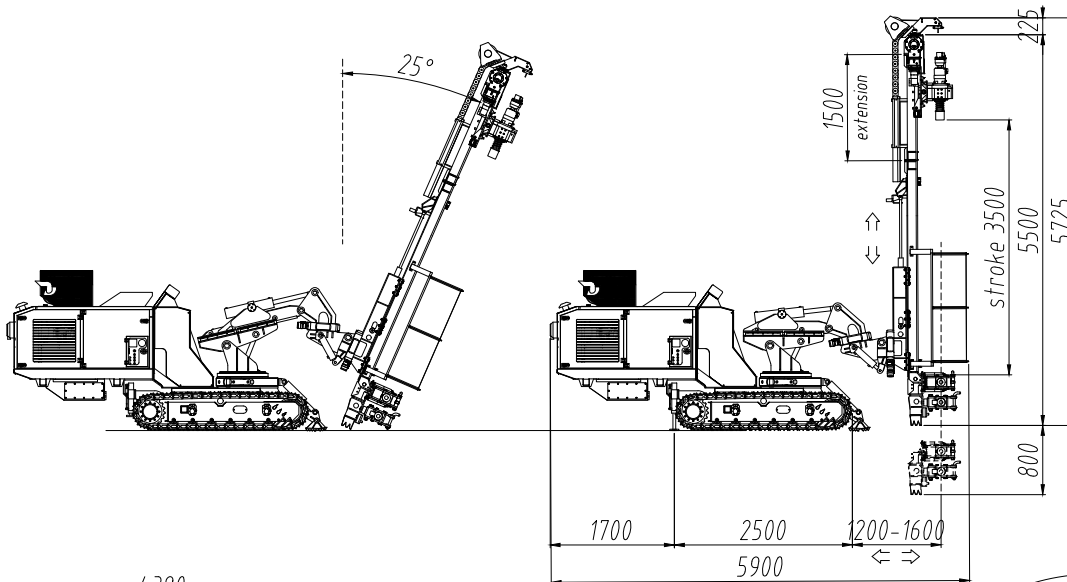

Perforazione in verticale e area di lavoro / vertical drilling - working area
forage vertical et zone de travail / vertikalbohrung und arbeitsbereich

MR - C 50

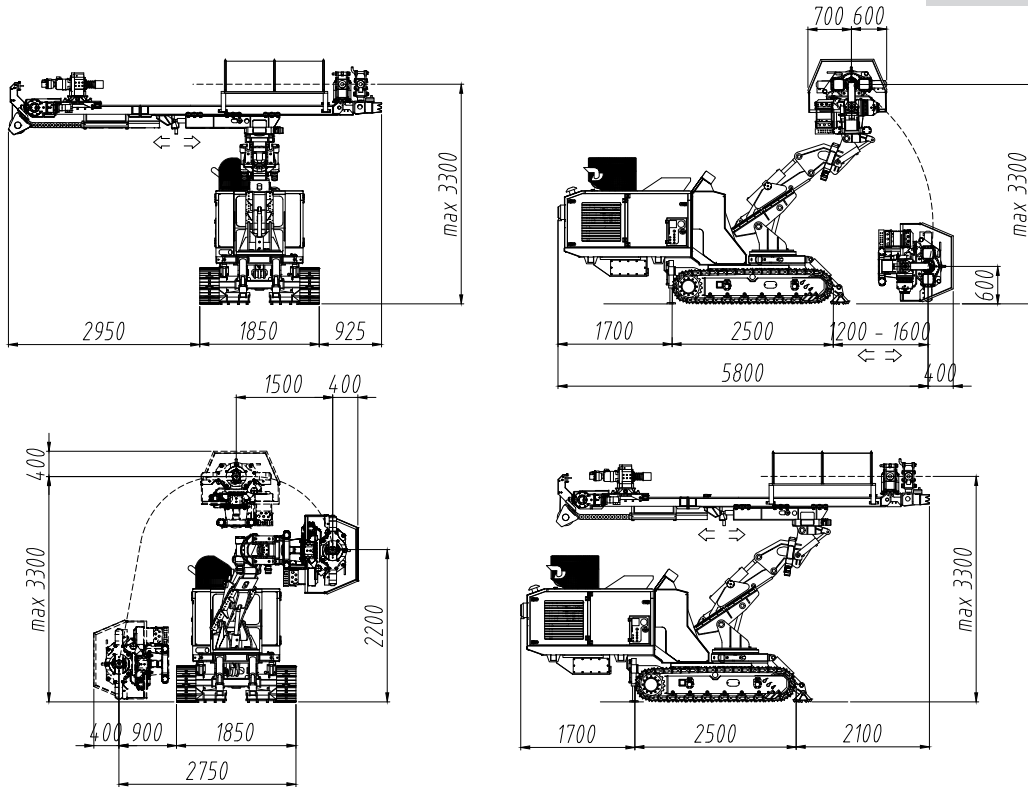

Versione con centrale idraulica separabile / version with separable hydraulic unit
 version avec groupe hydraulique séparable / Version mit trennbarem Hydraulikaggregat

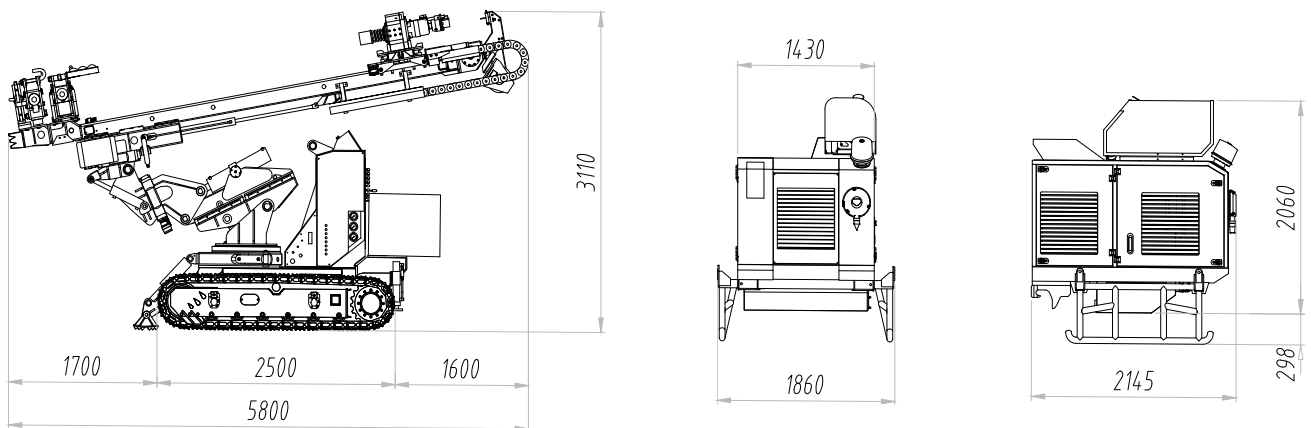

Perforatrice cingolata / crawler drilling rig
 foreuse sur chenille / bohrlafette mit fahrwerk

Centrale idraulica / hydraulic power pack
 Antriebseinheit / Centrale hydraulique

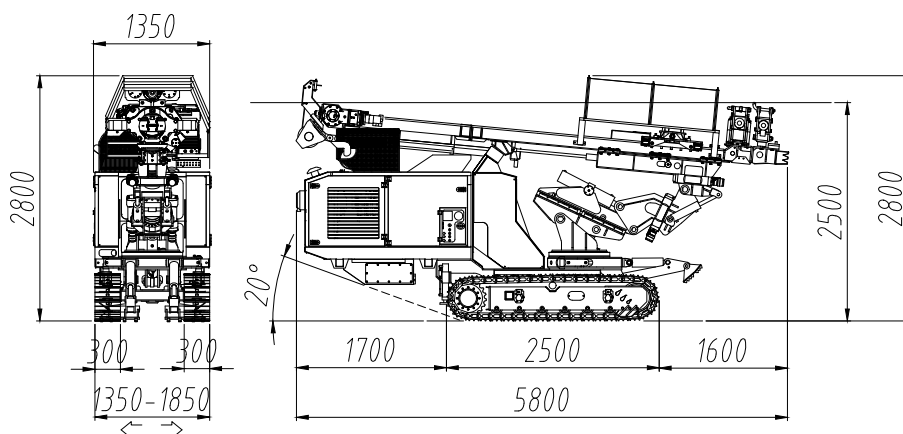

Peso totale unità / Machine total weight / Gesamtgewicht der Einheit / Poids total de l'unité
 ~ 9000 kg (19850 lbs)

MARINI[®] QUARRIES GROUP

... working to grow together...

MARINI QUARRIES GROUP S.R.L.

Via Beura 44-28844 Villadossola (VB)-ITALY

Tel. +39 0324 575106 Fax. +39 0324 54096

Web site www.mariniqg.it

email: mariniqg@mariniqg.it

