

MARINI

QUARRIES GROUP

MR - C 35



PERFORATRICE IDRAULICA
HYDRAULIC DRILLING
FOREUSE HYDRAULIQUE
HYDRAULISCHE BOHRMASCHINE

MR
NEW ERA OF DRILLING MACHINES

MR - C Line

IT

MR- C 35 è una piccola macchina da perforazione cingolata con centrale idraulica separabile, ottimizzata per tutti i lavori di ingegneria civile, carotaggi, micropali, ancoraggi e consolidamenti. Adatta al lavoro in spazi stretti e di difficile accesso, è dotata di una centrale idraulica in grado di erogare 75 Hp per azionare ogni tipo di perforatrice idraulica o martello fondo foro ed eseguire ogni tipo di perforazione.

ENG

MR- C 35 is a small mobile drilling unit on tracks with separate hydraulic power pack, optimized for all the works of civil engineering, core drilling, micro piles, anchors and consolidations. Suitable to work in narrow spaces and difficult to access, it is equipped with a hydraulic station able to provide 75Hp, to operate any kind of hydraulic rock-drill or down-the-hole hammer and perform any type of drilling job.

DE

MR- C 35 ist eine sehr kompakte Bohrraube für Einsätze im Spezialtiefbau. Arbeiten wie Kernloch-, Überlagerungs-, Anker- und Mikropfahlbohrungen bis Durchmesser 218 mm sind in engsten Platzverhältnissen möglich. Die enorme Flexibilität und Beweglichkeit ermöglicht hierbei nahezu jede erdenkliche Bohrposition. Das separat abkoppelbare Kraftpaket wird durch einen modernen, emissionsarmen Diesel mit 75 SP angetrieben.

FR

MR- C 35 est une petite unité de forage mobile sur les pistes avec bloc d'alimentation hydraulique séparé, optimisé pour tous les travaux de génie civil, carottage, micropieux, ancrages et consolidations. Convient pour travailler dans des espaces étroits et difficiles d'accès, il est équipé d'une station hydraulique capable de fournir 75 Hp, pour faire fonctionner tout type de roche-foreuse hydraulique ou marteau fond de trou et d'effectuer tout type de travail de forage.



MR - C 35

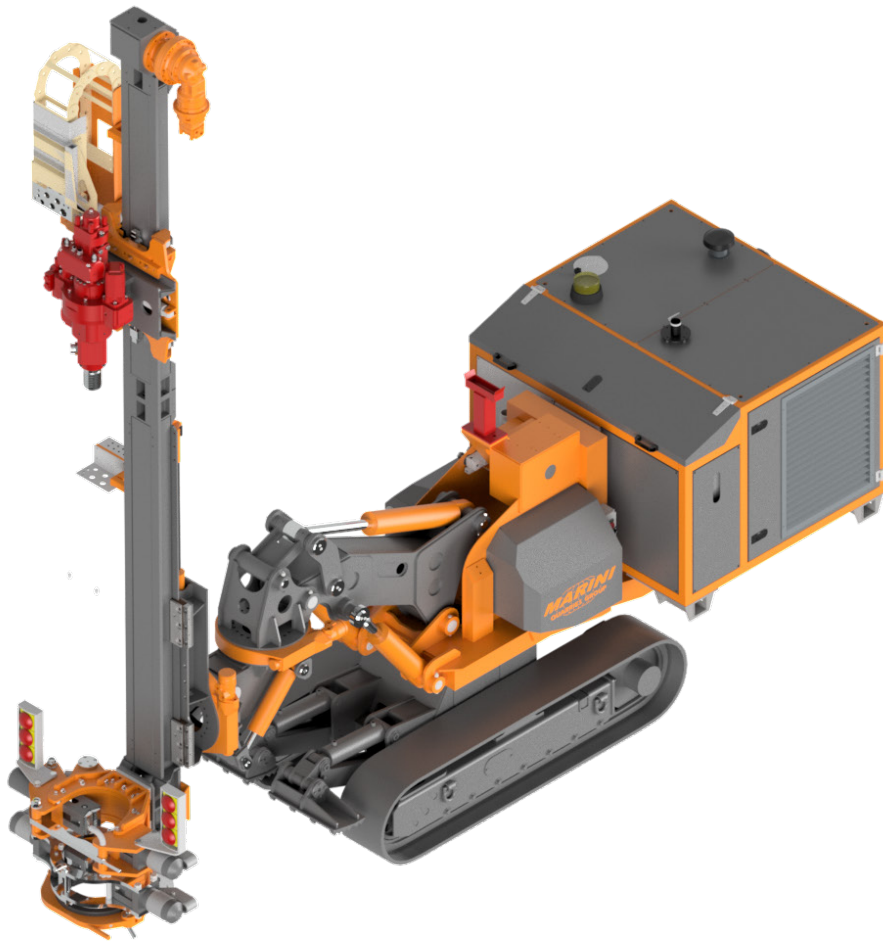

MR - C 35A removable mast

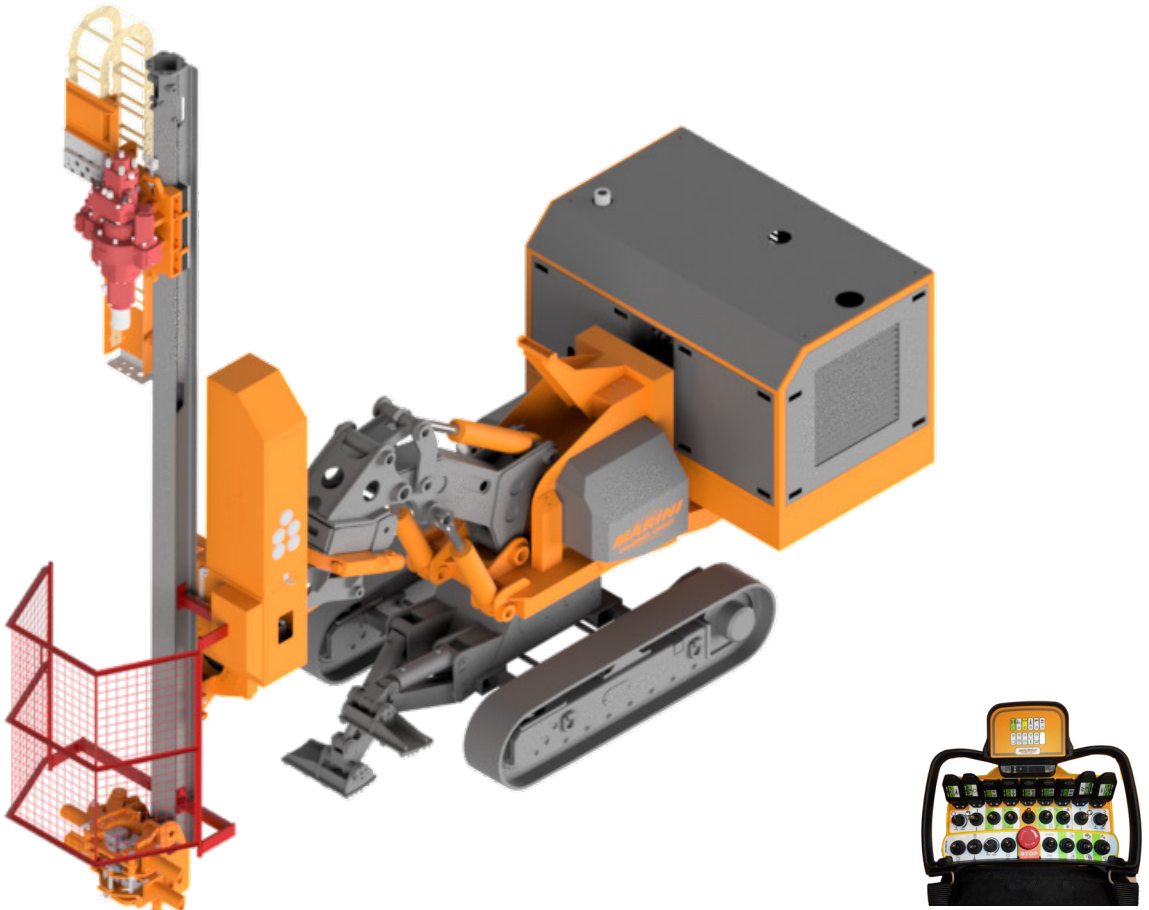

MARINI QUARRIES GROUP S.R.L.

Dati Tecnici- Technical Data- Caractéristiques Technique- Technische Daten

Carro Cingolato Undercarriage	Chariot chenille Fahrwerk			
Passo cingolo Wheel base	Enpattement Fahrwerk	1570 mm (5.15 ft)		
Careggiata Track	Standbreite Voie	1700 (5.57 ft)	optional 1200 / 1700 mm (3.94 / 5.57ft)	
Larghezza soles Pad width	Langeur patins Fussbreite	300 mm (0.98 ft)		
Pendenza max. Max. climbing ability	Pente max. Steigfähigkeit max.	80%		
Velocità max. Max. speed	Vitesse max. Fahrgeschwindigkeit	2 Km/h (1.25 mph)		
Centrale idraulica Power Pack	Groupe Hydraulique Hydraulikaggregat	Motore Diesel / Diesel Engine Moteur diesel / Dieselmotor		
Motore Engine	Moteur Motor	Kohler KDI 2504 TCR		
Potenza motore Engine Power	Puissance moteur Antriebsleistung	55kW (75 Hp) @2900 rpm		
Pompa principale Main pump	Pompe principale Hydraulische Leistung	160 lpm @ 200 bar (42.26 gal/min @2900 psi)		
Serbatoio olio Oil tank	Réservoir huile Oiltank	200 Litri (52.83 gal)		
Serbatoio Gasolio Fuel Tank	Réservoir diesel Diesel tank	100 Litri (26.42 gal)		
Consumo carburante Fuel consumption	Consommation de carburant Kraftstoffverbrauch	5 l/h (1.31 gal/h)		
Raffreddamento Cooling	Kühlung Refroidissement	Scambiatore aria olio separato - Separate oil air exchanger Luftaustauscher / Ölabscheider / échangeur		
Mast Mast	Mat Lafette	CID 120 (MR-C 35A)	CID 250 (Modular mast)	
Corsa utile Feed stroke	Course utile Vorschub	3500 mm (*) / 11.48 ft (*)	3300 mm (*) / 10.80 ft (*)	
Lunghezza totale Total length	Longueur totale Gesamtlänge	5400 mm (*) / 17.72 ft (*)	5350 mm (*) / 17.55 ft (*)	
Forza di spinta Feed force	Poussée Vorschubkraft	2000 daN / 4496 lbf	3500 daN / 7868 lbf	
Forza di tiro Retract force	Traction Rückzugskraft	2500 daN / 5620 lbf	3500 daN / 7868 lbf	
Teste di rotazione Rotary head	Tête de rotation Drehkopf	ID 500	ID 800	
Coppia max. Max. torque	Couple max. Drehmoment max.	500/250 daNm (3688/1844 lbft)	330/660 daNm (2434/4868 lbft)	500/1000 daNm (3688/7376 lbft)
Giri max. Max. speed	Vitesse max. Drehzahl max.	40/80 rpm	140/70 rpm	90/45 rpm
Marce Gears	Vitesses Gänge	2	2	
Passaggio testa Head passage	Passege de la tête Drehkopfdurchgang	1 "	1 ½"	
Perforatore Rock drill	Perforateur Bohrer	MA 100 / 2 ID	MA 500 / 2 ID	
Coppia max. Max. torque	Couple max. Drehmoment max.	100 daNm / 737 lbft	500 / 250 daNm (3688 / 1844 lbft)	
Giri max. Max. speed	Vitesse max. Drehzahl max.	100 rpm	40 / 80 rpm	
Energia di impatto Impact energy	Force de frappe Einzelschlagenergie	150 Nm / 110 ft lbf	320 Nm / 237 ft lbf	
Frequenza di battuta Impact frequency	Fréquence de frappe Schlagfrequenz	3200 cpm	2100 ÷ 2300 cpm	
Aste filettate ed auto perforanti Threaded and self-anchoring rods	Barres filetées et autoforeuses Gewindestangen und Bohr- schrauben	R32/R38/R51/ ISCHEBECK TITAN 30/40/52	R25/R32/R38/R51 ISCHEBECK TITAN 30/40/52	
(*) dimensioni variabili su richiesta / dimension variable on request/ dimensions variables sur demande/ variable abmessungen auf anfrage				

Morse Clamps	Mors Klemm-und Brechvorrichtung	Mod: 70/188	Mod: 70/230
Diametro min. / max presa Clamping range	Tige diamètre min. / max Durchmesser min. / max	Ø 25 / 188 mm (0.98 / 7.40 in)	Ø 25 / 230 mm (0.98 / 9 in)
Forza di chiusura Clamping force	Force de serrage Klemmkraft	18000 daN @220 bar (40465 lb @ 3191 psi)	
Coppia svitaggio Breaking torque	Couple de deserrage Brechmoment	4000 daNm / 28933 lb ft	
Argano idraulico Hydraulic winch	Treuil hydraulique Hydraulische Seilwinde	Mod: 500	Mod: 1000
Tiro max. Max. pull	Max. Zugkraft Traction maxi	500 daN / 1124 lb	1000 daN / 2200 lb
Lunghezza fune Rope length	Seillänge Longueur du câble	20 mt. (*) / 65.6 ft (*)	30 mt. (*) / 100 ft (*)
Diametro filo Rope diameter	Seildurchmesser Diamètre du fil	6 mm / 0.236 in	8 mm / 0.31 in
Carrello Apribile Openable cart	Chariot ouvrable Öffnungskorb	Mod: CA	
Corsa utile Feed stroke	Course utile Vorschub	440 mm (*) / 17.23 in (*)	
Gabbia di protezione Protection cage	Cage de protection Schutzkäfig	Mod: M	Mod: R
Apertura opening	Ouverture Öffnung	Manuale /Manual Manuelle/Manuelle	Radiocomandata /Radio-controlled Radio-pilotée /Funkgesteuerte
Teste di rotazione Rotary head	Tête de rotation Drehkopf	ID CD SPECIAL Carotaggio / Coring / Carottage / Entkernungs	
Coppia max. Max. torque	Couple max. Drehmoment max.	26 daNm / 191.8 lbft	
Giri max. Max. speed	Vitesse max. Drehzahl max.	600 rpm	
Marce Gears	Vitesses Gänge	1	
Passaggio testa Head passage	Passege de la tête Drehkopfdurchgang	1"	
Centrale idraulica Power Pack	Groupe Hydraulique Hydraulikaggregat	Motore Elettrico / Electric motor Moteur électrique / Elektromotor	
Potenza motore Engine Power	Puissance moteur Antriebsleistung Leistung	45kW (60Hp) @2900 rpm	
Pompa principale Main pump	Pompe principale Hydraulische Leistung	120 lpm @ 200 bar (31.70 gal/min @2900 psi)	
Serbatoio olio Oil tank	Réservoir huile Öltank	150 Litri (39.6 gal)	
Raffreddamento Cooling	Kühlung Refroidissement	Scambiatore aria olio separato - Separate oil air exchanger Luftaustauscher / Ölabscheider / échangeur	



MR - C 35

Movimenti Mast (mm)- Mast Movements (mm)- Cinématique du Bras (mm)- Volle Gelenkmöglichkeit (mm)

Perforazione frontale - avanzamento / Front - forward drilling / Forage frontal - avancement / Front Bohren - Fortschritt

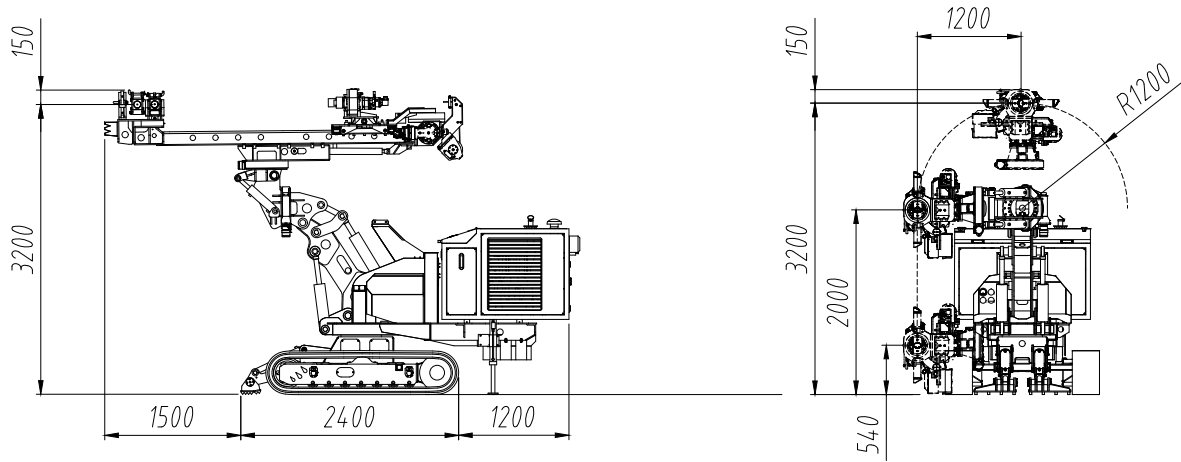

Perforazione in orizzontale e area di lavoro / Horizontal drilling - working area / Forage horizontal et zone de travail / Horizontalbohrung und arbeitsbereich

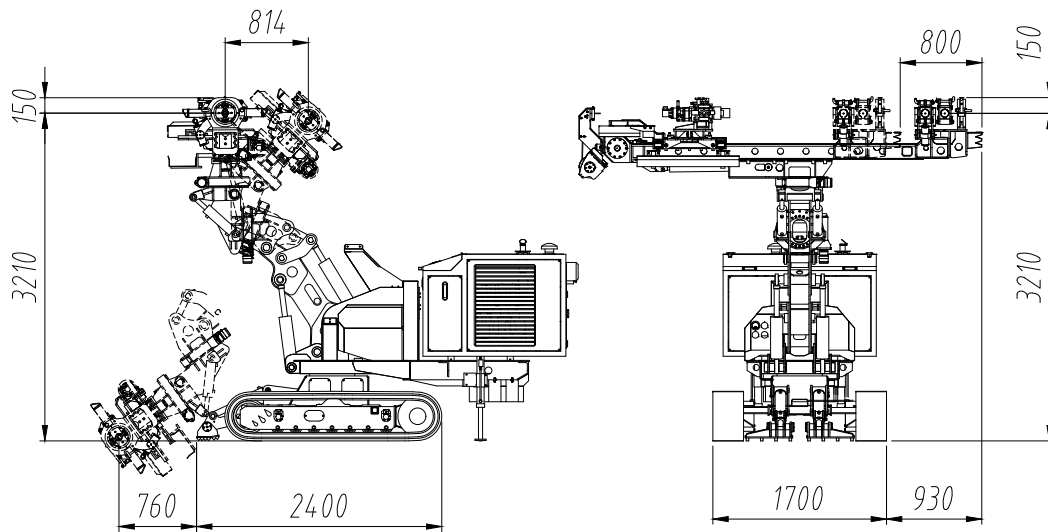

Perforazione in verticale e area di lavoro / Vertical drilling - working area / Forage vertical et zone de travail / Vertikalbohrung und arbeitsbereich

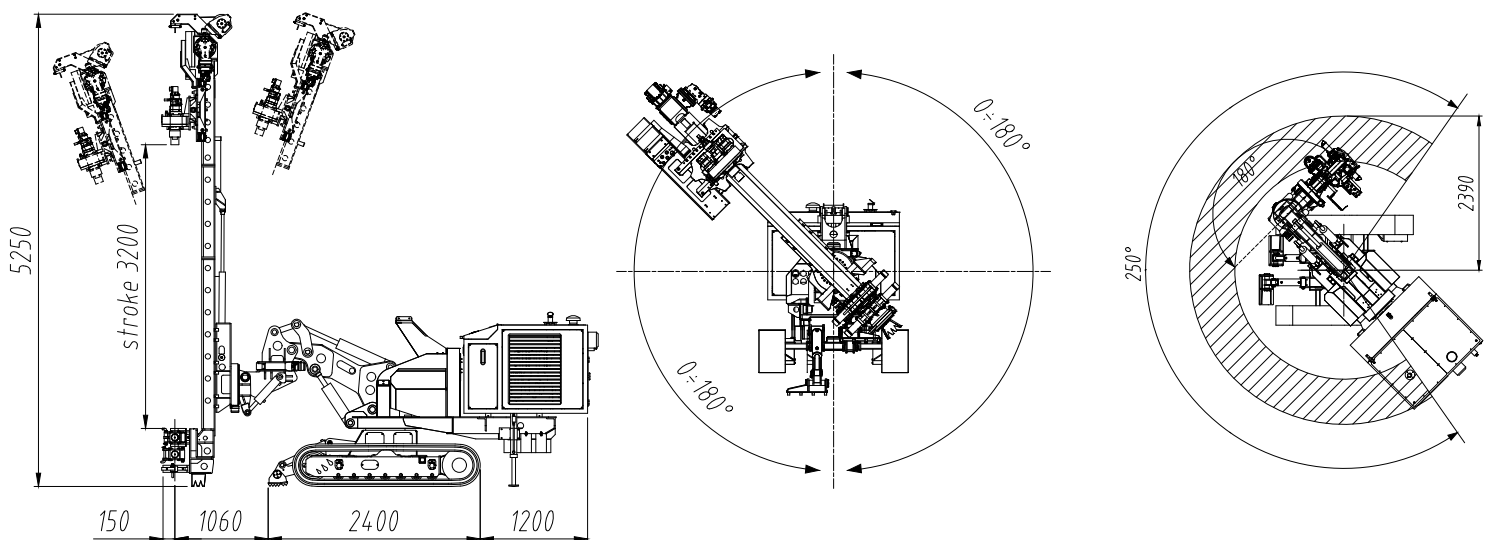

MR - C 35

Posizione di trasporto / Transport position / Position de transport / Transportposition

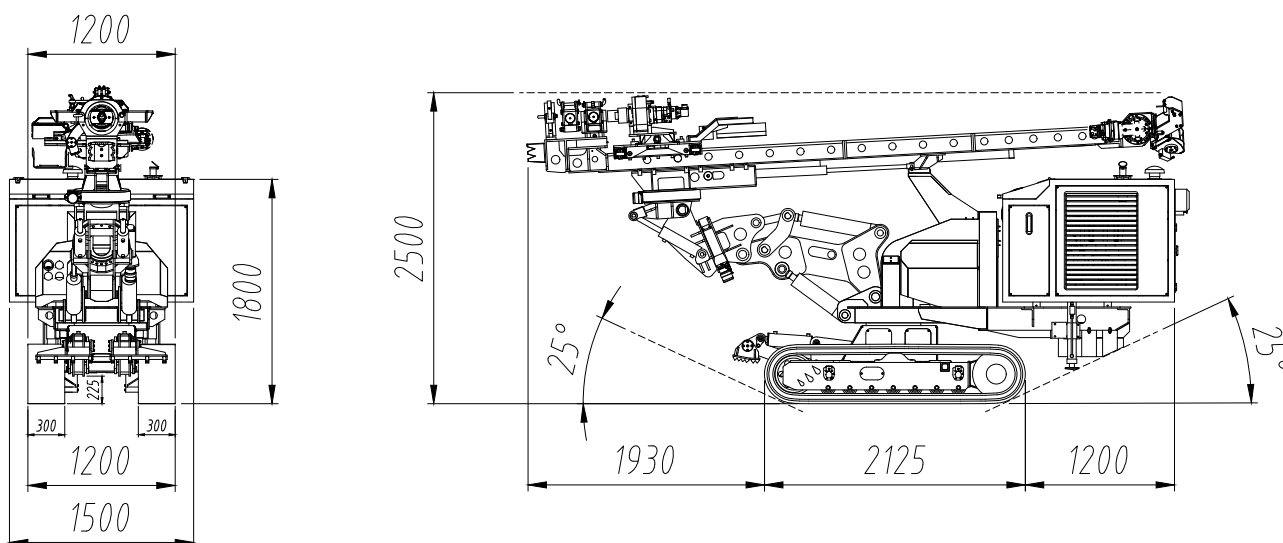

Peso Unità / Unit weight / Poids total de l'unité / Gesamtgewicht der Einheit:
~6500 Kg / 14329 lb



MARINI[®] QUARRIES GROUP

... working to grow together...

MARINI QUARRIES GROUP S.R.L.

Via Beura 44-28844 Villadossola (VB)-ITALY

Tel.+39 0324 575106 Fax. +39 0324 54096

Web site www.mariniqg.it

email: mariniqg@mariniqg.it

