

MARINI

QUARRIES GROUP

MR - C 10



PERFORATRICE IDRAULICA
HYDRAULIC DRILLING RIG
FOREUSE HYDRAULIQUE
HYDRAULISCHE BOHRMASCHINE

MR
NEW ERA OF DRILLING MACHINES

MR - C Line

IT

MR- C 10 Unità mobile da perforazione per l'esecuzione di fori orizzontali, verticali o inclinati. Struttura semovente equipaggiata con cingoli in gomma e azionata da centralina idraulica 23 HP diesel o benzina (motore elettrico a richiesta). Sul MR- C 10 è possibile montare una testa di rotazione per martello fondo foro da 350 daNm di coppia (MARINI modello ID300) , oppure una testa per carotaggio (MARINI modello ID CD), oppure una perforatrice a rotazione separata (MARINI modello MA100).

ENG

MR- C 10 Mobile drilling unit suited to execute vertical, horizontal or inclined holes. Self moving wagon unit with rubber tracks, powered by a hydraulic power pack with 23 hp diesel or petrol motor (electric motor upon request). The MR- C 10 can be equipped with a DTH hammer rotary head torque 350 Nm (MARINI mod. ID300), a coring head (MARINI mod. ID CD) or rock-drill with separated rotation (MARINI mod. MA100).

DE

MR- C 10 Von der mobilen Einheit für die Ausführung von horizontalen Bohrungen, vertikalen oder geneigten Bohren. ausgestattet mit Selbstantrieb Rahmen mit Gummiketten und durch Hydraulikaggregat 23 PS-Diesel oder Benzin (Elektromotor auf Anfrage erhältlich) angetrieben. Auf MR- C 10 Technik können Sie einen Drehkopf für Bohrloch-Drehmoment von 350 daNm (MARINI ID300 Modell) montieren oder einen Kopf Drilling (MARINI Modell CD-ID) oder eine Bohrmaschine zu trennen Rotation (MARINI MA100).

FR

MR- C 10 Unité de perçage mobile pour le perçage de trous horizontaux, verticaux ou inclinés. Structure auto-motrice équipée de chenilles à chenilles en caoutchouc et entraînée par commande hydraulique diesel ou essence 23 CV (moteur électrique sur demande). Le MR- C 10 peut être équipé d'une tête de forage de 350 daNm (modèle MARINI ID300) ou d'une tête de forage (modèle MARINI ID CD) ou d'une perceuse rotative séparée (modèle MARINI MA100).



MR - C 10



Dati Tecnici- Technical Data- Caractéristiques Technique- Technische Daten

Carro Cingolato Undercarriage	Chariot chenille Fahrwerk		
Passo cingolo Wheel base	Enpattement Fahrwerk	1080 mm (3.54 ft)	
Careggiata Track	Standbreite Voie	1000 mm (3.28 ft)	
Larghezza suole Pad width	Langeur patins Fussbreite	230 mm (0.75 ft)	
Pendenza max. Max. climbing ability	Pente max. Steigfähigkeit max.	80%	
Velocità max. Max. speed	Vitesse max. Fahrgeschwindigkeit	1.67 Km/h (1.06 mph)	
Centrale idraulica Power Pack	Groupe Hydraulique Hydraulikaggregat	Motore Diesel / Diesel Engine Moteur diesel / Dieselmotor	Motore Elettrico / Electric motor Moteur électrique / Elektromotor
Motore Engine	Moteur Motor	Lombardini LDW 1003	
Potenza motore Engine Power	Puissance moteur Antriebsleistung	17kW (23 Hp) @3000 rpm	15kW (20 Hp) @2900 rpm
Pompa principale Main pump	Pompe principale Hydraulische Leistung	40 lpm @ 200 bar (10.56 gal/min @2900 psi)	
Serbatoio olio Oil tank	Réservoir huile Oiltank	50 Litri (13.2 gal)	
Serbatoio Gasolio Fuel Tank	Réservoir diesel Diesel tank	20 Litri (5.28 gal)	/
Consumo carburante Fuel consumption	Consommation de carburant Kraftstoffverbrauch	2.5 l/h (0.66 gal/h)	/
Raffreddamento Cooling	Kühlung Refroidissement	Scambiatore aria olio separato - Separate oil air exchanger Luftaustauscher / Ölabscheider / échangeur	
Mast Mast	Mat Lafette	CID 100	
Corsa utile Feed stroke	Course utile Vorschub	1760 mm (*) / 5.77 ft (*)	
Lunghezza totale Total length	Longueur totale Gesamtlänge	3225 mm (*) / 10.58 ft (*)	
Forza di spinta Feed force	Poussée Vorschubkraft	1000 daN / 2248 lbf	
Forza di tiro Retract force	Traction Rückzugskraft	1500 daN / 3372 lbf	
Teste di rotazione Rotary head	Tête de rotation Drehkopf	ID 160	ID 300
Coppia max. Max. torque	Couple max. Drehmoment max.	160 daNm / 1180 lbft	350 daNm / 2581 lbft
Giri max. Max. speed	Vitesse max. Drehzahl max.	60 rpm	40 rpm
Marce Gears	Vitesses Gänge	1	1
Passaggio testa Head passage	Passege de la tête Drehkopfdurchgang	1"	1"
Perforatore Rock drill	Perforateur Bohrer	MA 100 S ID	
Coppia max. Max. torque	Couple max. Drehmoment max.	100 daNm / 737 lbft	
Giri max. Max. speed	Vitesse max. Drehzahl max.	100 rpm	
Energia di impatto Impact energy	Force de frappe Einzelschlagenergie	180 Nm / 132 ft lbf	
Frequenza di battuta Impact frequency	Fréquence de frappe Schlagfrequenz	2800 cpm	
Aste filettate ed auto perforanti Threaded and self-anchoring rods	Barres filetées et autoforeuses Gewindestangen und Bohrschrauben	R32/R38/R51/T38/T45/H55 LH-RH /H64 LH-RH	
(*) dimensioni variabili su richiesta / dimension variable on request/ dimensions variables sur demande/ variable abmessungen auf anfrage			

Opzioni ed Accessori- Options and Accessories- Options et Accessoires- Optionen und Zubehör

Morse Clamps	Mors Klemm-und Brechvorrichtung	Mod: 25/115	Mod: 70/188
Diametro min. / max presa Clamping range	Tige diamètre min. / max Durchmesser min. / max	Ø 25 / 115 mm (0.98 / 4.5 in)	Ø 25 / 188 mm (0.98 / 7.40 in)
Forza di chiusura Clamping force	Force de serrage Klemmkraft	7000 daN @220 bar (15737 lb @ 3191 psi)	18000 daN @220 bar (40465 lb @ 3191 psi)
Coppia svitaggio Breaking torque	Couple de deserrage Brechmoment	/	4000 daNm / 28933 lb ft
Argano idraulico Hydraulic winch	Treuil hydraulique Hydraulische Seilwinde	Mod: 500	
Tiro max. Max. pull	Max. Zugkraft Traction maxi	500 daN / 1124 lb	
Lunghezza fune Rope length	Seillänge Longueur du câble	20 mt. (*) / 65.6 ft (*)	
Diametro filo Rope diameter	Seildurchmesser Diamètre du fil	6 mm / 0.236 in	
Carrello Apribile Openable cart	Chariot ouvrable Öffnungskorb	Mod: Manuale /Manual / Manuelle/Manuelle	
Corsa utile Feed stroke	Course utile Vorschub	/	
Gabbia di protezione Protection cage	Cage de protection Schutzkäfig	Mod: M	
Apertura opening	Ouverture Öffnung	Manuale /Manual Manuelle/Manuelle	
Teste di rotazione Rotary head	Tête de rotation Drehkopf	ID CD SPECIAL Carotaggio / Coring / Carottage / Entkernungs	
Coppia max. Max. torque	Couple max. Drehmoment max.	26 daNm / 191.8 lbft	
Giri max. Max. speed	Vitesse max. Drehzahl max.	600 rpm	
Marce Gears	Vitesses Gänge	1	
Passaggio testa Head passage	Passege de la tête Drehkopfdurchgang	1"	



MR - C 10

Movimenti Mast (mm)- Mast Movements (mm)- Cinématique du Bras (mm)- Volle Gelenkmöglichkeit (mm)

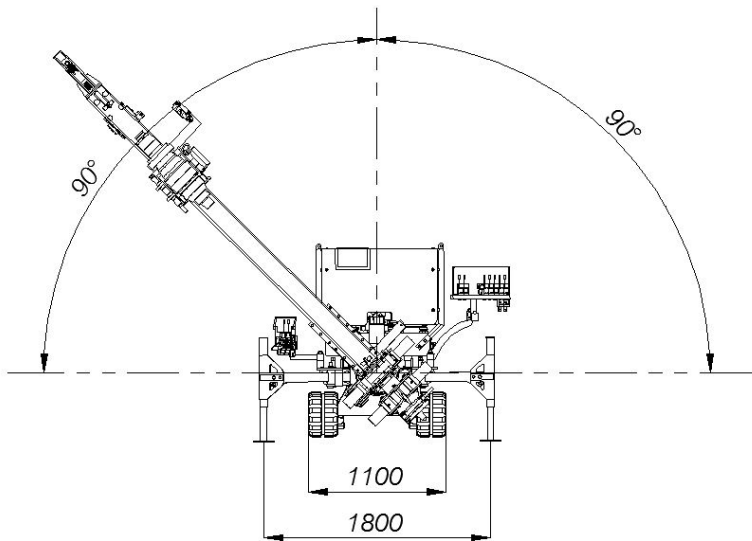
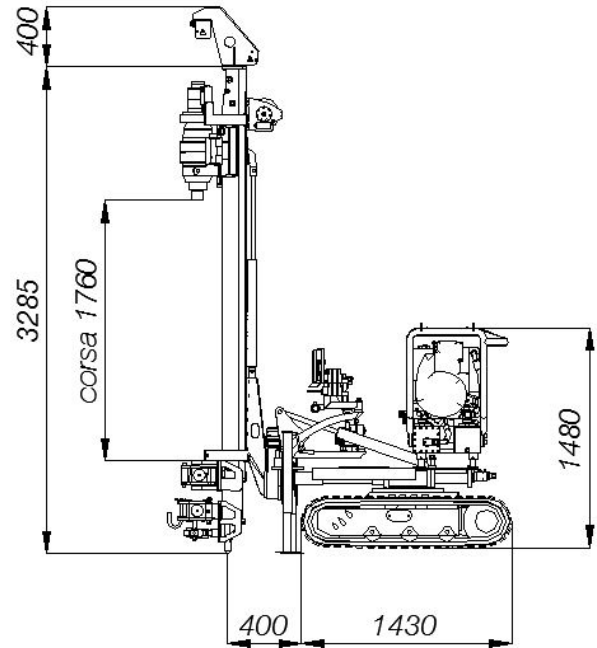
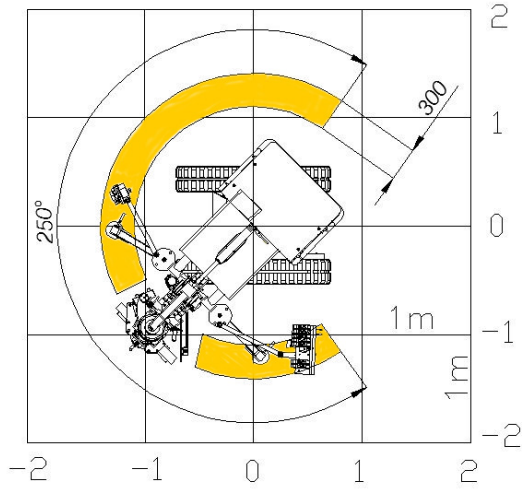

Perforazione in verticale e area di lavoro / vertical drilling - working area
forage vertical et zone de travail / vertikalbohrung und arbeitsbereich

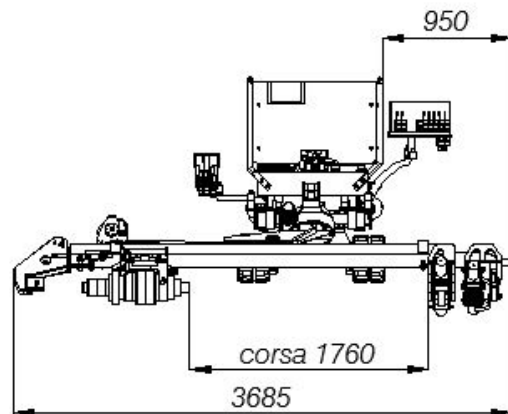
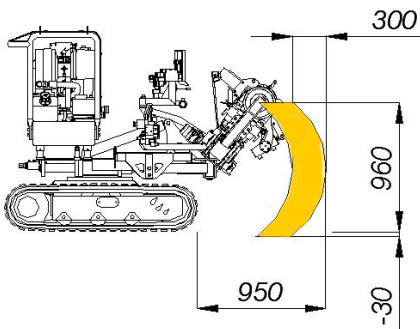

perforazione in orizzontale e area di lavoro / horizontal drilling - working area
forage horizontal et zone de travail / horizontalbohrung und arbeitsbereich

MR - C 10

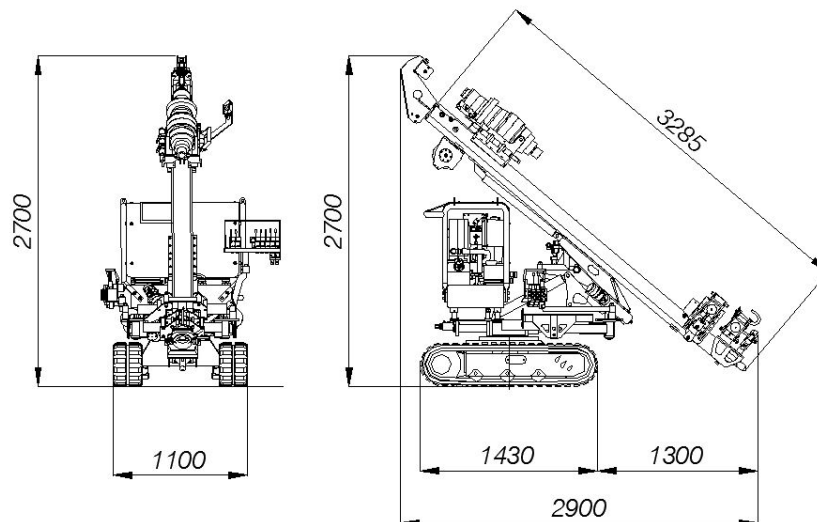
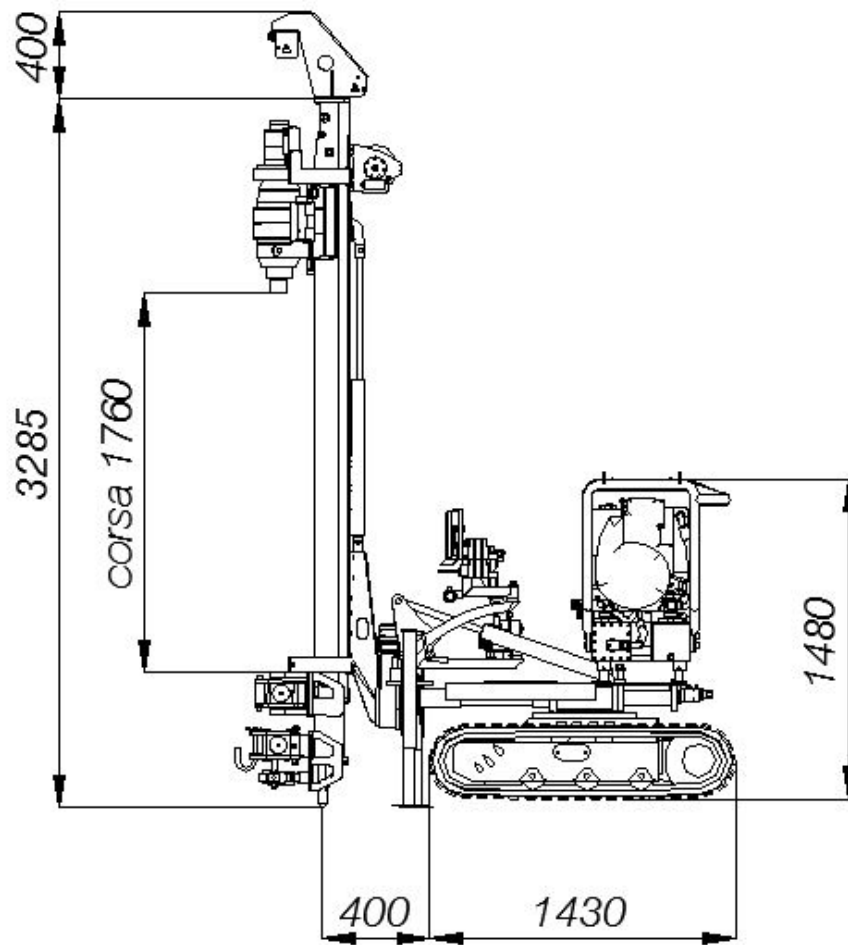

Peso totale unità /Machine total weight /Gesamtgewicht der Einheit/Poids total de l'unité
~ 1300 kg (2866 lbs)

MARINI[®]

QUARRIES GROUP

... working to grow together...

MARINI QUARRIES GROUP S.R.L.

Via Beura 44-28844 Villadossola (VB)-ITALY

Tel. +39 0324 575106 Fax. +39 0324 54096

Web site www.mariniqg.it

email: mariniqg@mariniqg.it

