

# GROUND IMPROVEMENT EQUIPMENT

For stone columns and vibro compaction



PTC masters vibration technology since more than 90 years.

This know-how has been applied to the field of ground improvement, to develop a complete range of Vibrolance solutions for Vibro compaction and stone columns.



## WORLD LEADING COMPANY

---

PTC is a company specialised in the design and manufacturing of piling and ground improvement equipment.

Our agent network, which is present in more than 40 countries, is supported from our head office in France, and our two subsidiaries in Singapore, Middle East.

This large international presence allows us to guarantee sales and technical support worldwide.

## SUPPORT FROM THE PROJECT TO THE JOBSITE

---

Our sales, engineering and service teams, work in cooperation with our clients throughout all the project phases:

- Geo-technical and engineering advise
- Equipment selection
- Customisation requirements
- Equipment commissioning
- On-site training
- Maintenance and after sales service
- Spare parts availability



# OVERVIEW

## Ground improvement techniques with Vibrolance.

When land is reclaimed from the seabed or the in-situ soil does not fulfil the requirements of bearing capacity, lateral stability and liquefaction potential, ground improvement techniques with Vibrolance offer a qualitative and economical solution.

Soil treatment with Vibrolance is adapted for a wide variety of ground conditions and can be carried out to almost any depth. The execution is fast and enables large volumes of soil to be improved, allowing subsequent structural works follow quickly.

Another advantage is the environmental friendliness, the soil is treated with natural materials, such as in-situ soil, stones or gravel, rather than with cement, bentonite or steel, used in other deep foundations.

The choice of the best-adapted technique will be determined mainly by the type of soil and the soil's water saturation and bearing capacity requirements.

The following graph illustrates the limits of application of the two main Vibrolance techniques: Vibro compaction and stone columns.

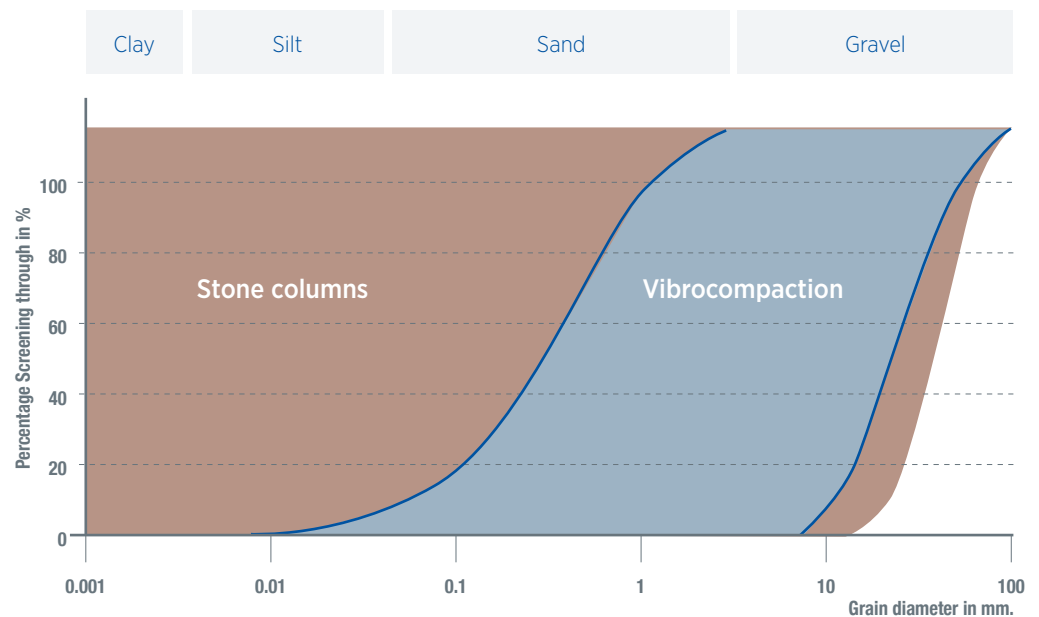

## VIBRO COMPACTION

---

This technique is used in granular soils. The Vibrolance® produces vibrations to rearrange the soil particles of non-cohesive soils into a denser state.

The action of the Vibrolance, usually accompanied by water jetting, reduces the inter-granular forces between the soil particles allowing them to move into a more compact configuration.



## STONE COLUMNS

---

This technique is mostly used for cohesive saturated soils. In some cases this technique can also be used for non cohesive soils. It consists in installing and compacting in the ground load bearing columns made of gravel or crushed stone, following a grid pattern previously determined by a test trial.

### TOP FEED METHOD

---

The column is build with stones that are added from the ground surface into the hole created by the Vibrolance. To do this, the Vibrolance must be withdrawn from the ground several times to allow the addition of the stones and re-inserted to assure the compaction.



### BOTTOM FEED METHOD

---

The column is done with compacted stones that are fed from the bottom of the column (at desired depth), thanks to a stone feeding tube at the tip of the Vibrolance.



# THE VIBROLANCE®

## DESCRIPTION & FEATURES

The Vibrolance® is a cylindrical hydraulic vibratory system, composed of a vibrator, an isolator and various extension tubes. The vibrator contains an eccentric that continuously oscillates, generating radial vibrations. These vibrations are used to penetrate the ground and then to treat the soil, according to the chosen ground improvement technique (vibro compaction or stone columns). 5 meter extension tubes allow the Vibrolance® to adjust to almost any treatment depth. Vibrolances can be equipped with a Bottom Feed System (BFS), for stone column applications. In this case, a stone tube and a stone tank with a stone gate, will be added to the Vibrolance®.

### EASY ON-SITE MAINTENANCE DESIGN

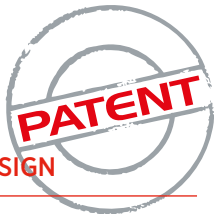

PTC Vibrolances have a patented design that allows easy access for fast on-site maintenance. It consists in dismantlable modules which are easy to take apart and reassemble, thus providing quick access to all internal parts of the vibrator (bearings, hydraulic motor, eccentrics and more)

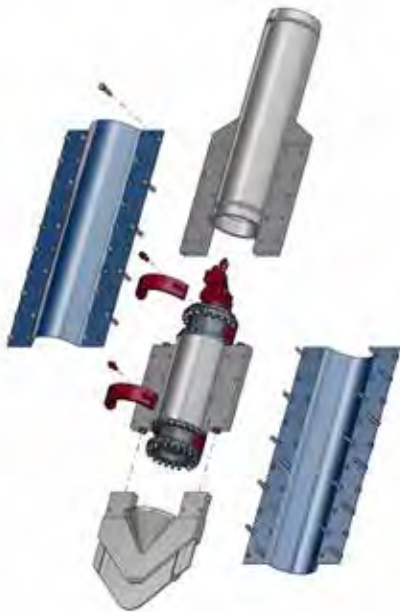

Vibrolance®

Vibrolance® BFS

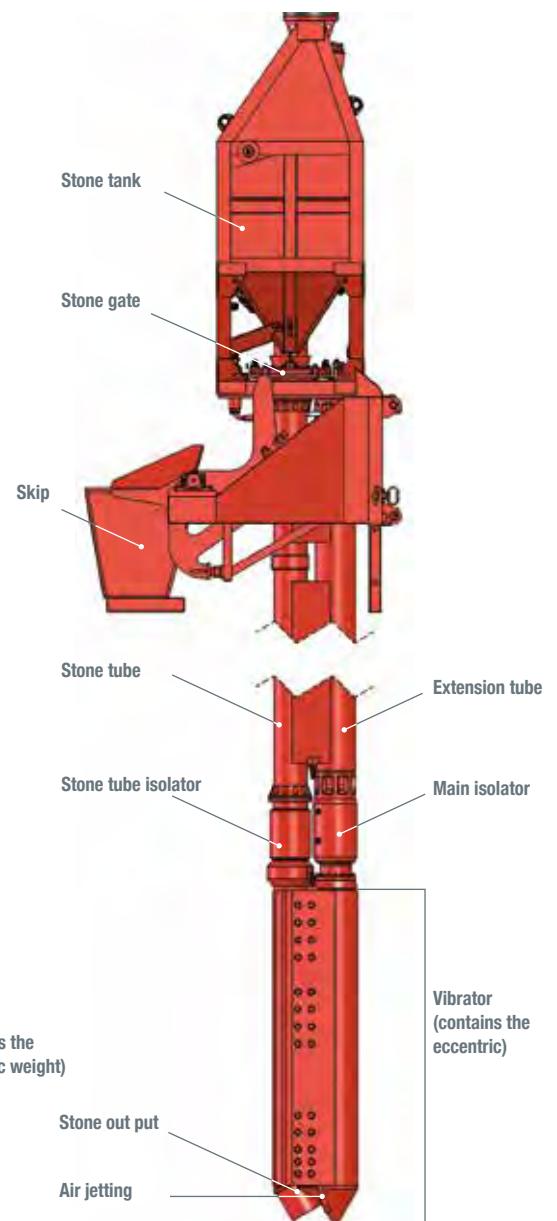
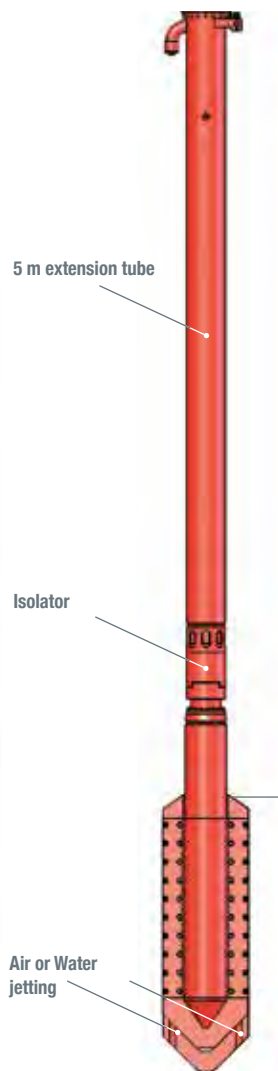

# THE WORKING PRINCIPLE

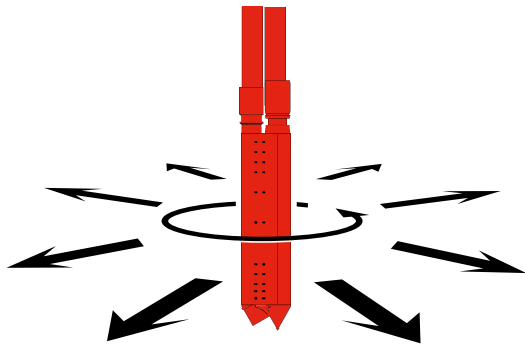

The eccentric in the vibrator generates radial vibrations. This vibrations, the pull down force (if it is mounted on a carrier) and the Vibrolance weight are used to penetrate the ground to the required treatment depth. The penetration can be assisted by water or air jetting at the tip of the Vibrolance.

During the extraction phase, the Vibrations of the Vibrolance are used to carry out the soil treatment, by agitating the soil particles and forcing them to rearrange in a denser state of compaction (vibro compaction), and/or by compacting a pile of stones installed in the ground (stone column).

Then to rearrange in a denser state of compaction (vibro compaction).  
And/or by compacting a pile of stones installed in the ground (stone column).

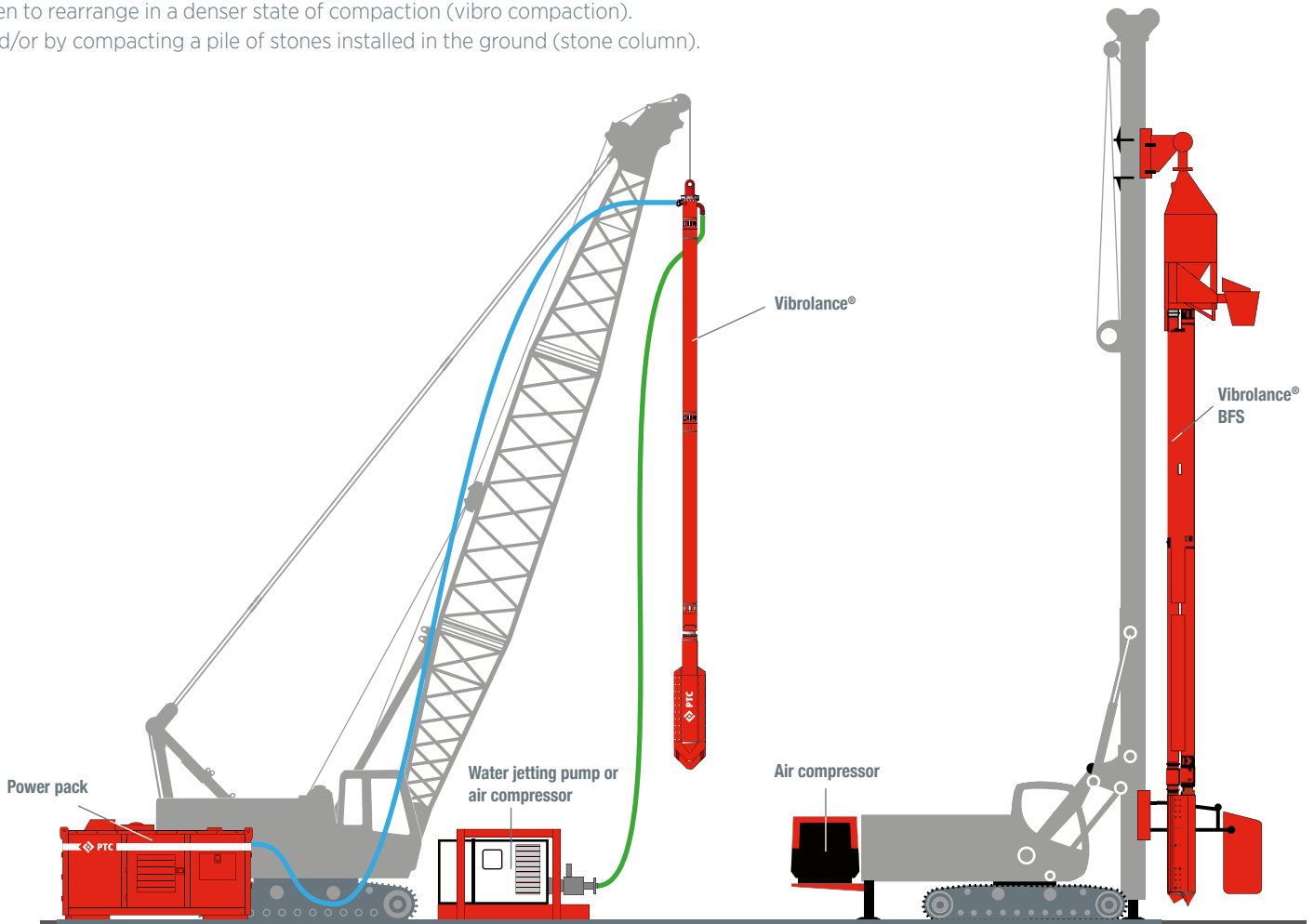

## Power source

When Vibrolances are used free hanging on a crane they are powered by a PTC Power Pack. When Vibrolances are mounted on rigs or excavators they can use the power source of the machine they are mounted on.

# VIBRO COMPACTION

## For land reclamation and sand compaction

The Vibro compaction technique is used in granular soils with limited fines content. This technique uses the Vibrolance® sustained vibrations to rearrange the soil particles of non-cohesive soils into a denser state. The action of the vibrator reduces the inter-granular forces between the soil particles, allowing them to move into a more compact configuration.

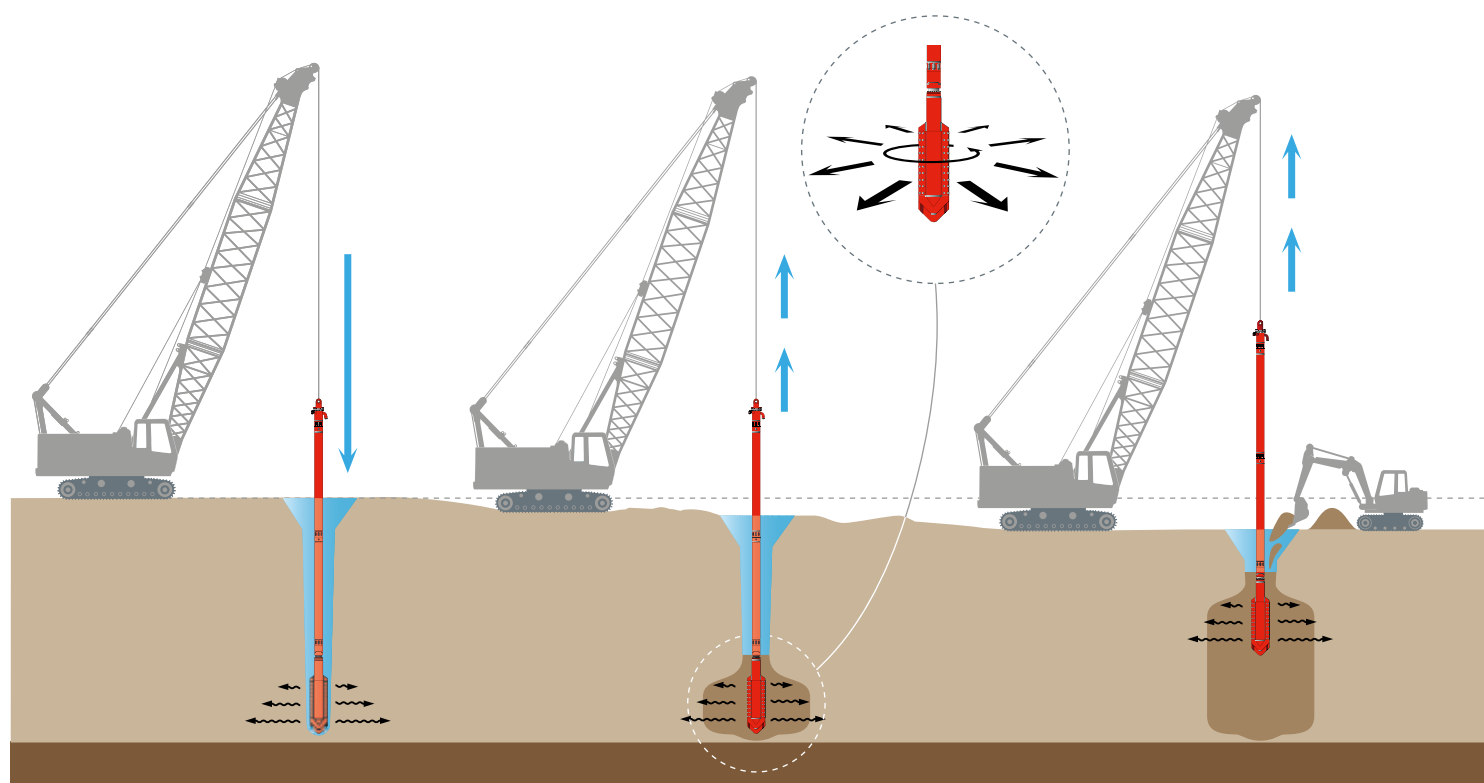

### 1. Penetration

The PTC Vibrolance penetrates the ground thanks to the combined effect of the vibrations emitted by the vibrator and the Vibrolance own weight.

The penetration is usually assisted by a water jetting system at the tip of the Vibrolance. The water reduces the interstitial pressure between the soil particles, thus reducing the friction with the soil.

### 2. Compaction

Once at depth the Vibrolance performs a series of compaction intervals, starting from maximum depth of penetration upwards. During compaction, the vibrolance sustained vibrations agitate the particles and force the soil to rearrange to a denser state of compaction. The compacted soil forms a cylinder around the vibrolance.

Side water jetting may be used to facilitate the extraction of the Vibrolance when the penetration depth surpasses 20m.

### 3. Backfilling

The densification of the soil lowers the surface level and forms a crater at the top of the Vibrolance insertion point. This gap is backfilled during the compaction process, either with imported or in-situ material, which is added to the Vibrolance insertion point.

The compaction and backfilling process are repeated until the Vibrolance reaches the surface and is completely extracted from the ground.



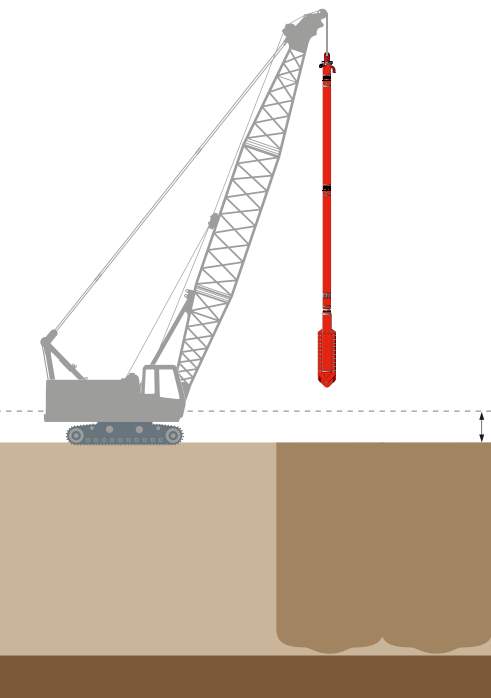

#### 4. Finishing

When the Vibrolance reaches the surface, the compacted ground has a cylindrical shape from the bottom to the top of the Vibrolance insertion point.

The Vibrolance will be re-inserted in the ground at the next spot of the compaction grid, until the treated soil reaches the degree of compaction required.

The compaction of the soil causes a decrease of the volume of up to 10%.

## OFFSHORE

The Vibro compaction can be used to compact the seabed, thanks to the extension tubes that can be adapted to the PTC Vibrolances to work under water for almost any treatment depth. Particularly interesting for reclaimed lands.

# VIBRO COMPACTION

## EQUIPMENT: VIBROLANCE VL18 - VL40 - VL110

PTC Vibrolance models can be adapted to the required treatment depth through the addition of 5 m extension tubes. Different mounting attachments are proposed for better adaption to the contractor's job site equipment.



VIBROLANCE®		VL18	VL40	VL110
ECCENTRIC MOMENT	m.kg	1.8	4.0	11.2
VIBROLANCE POWER	kW/HP	113 / 154	135 / 183	202 / 274
FREQUENCY	Hz/rpm	50 / 3000	30 / 1800	28 / 1680
CENTRIFUGAL FORCE	kN	181	145	353
WATER JETTING SYSTEM		Option	Option	Option
AIR JETTING SYSTEM		Option	Option	Option
<b>RECOMMENDED POWER PACK</b>				
MODEL		240	240	400

PTC reserves the right to modify the technical data without notice.

## AVAILABLE VERSION

CRANE  
SUSPENDED  
VL-F



EXCAVATOR  
MOUNTED  
VL-E



RIG  
MOUNTED  
VL-R



## APPLICATIONS

- Land reclamation: Treatment of soil reclaimed from the sea or lake, by dredging.
- Reduction of the liquefaction risk in seismic zones.
- Sand compaction: In-situ densification of loose sands.
- Offshore Vibro-compaction.



Two Vibrolances working in the compaction of 17 million m<sup>3</sup> reclamation sand at an underwater depth of 15 to 20 m. The soil improvement treatment is required for building a new 6 km long quay, **Singapore**.



Vibrolance VL110 working at 31 m depth to compact 2,000,000 m<sup>3</sup> of land reclamation for the extension of the LAMME power station, **Hong Kong**.



VL18 Vibrolance in a deep compaction works of a 7 m depth for a river bank stabilization in **Canada**.



7 sets of Vibrolances VL110 working at 12 m to 15 m compaction depth for a 500 acres sea bed land reclamation project, needed for the Pengerang Independent Deepwater Petroleum Terminal, **Malaysia**.

# STONE COLUMNS

## Top feed method.

The top feed stone columns are a vibro replacement technique recommended for cohesive saturated soils. This technique consists in building and compacting in the ground columns made from coarse gravel, crushed stone or crushed aggregate, following a grid pattern previously determined by a test trial. In the top feed method, the column is made with stones that are added from the ground surface into the hole created by the Vibrolance®.

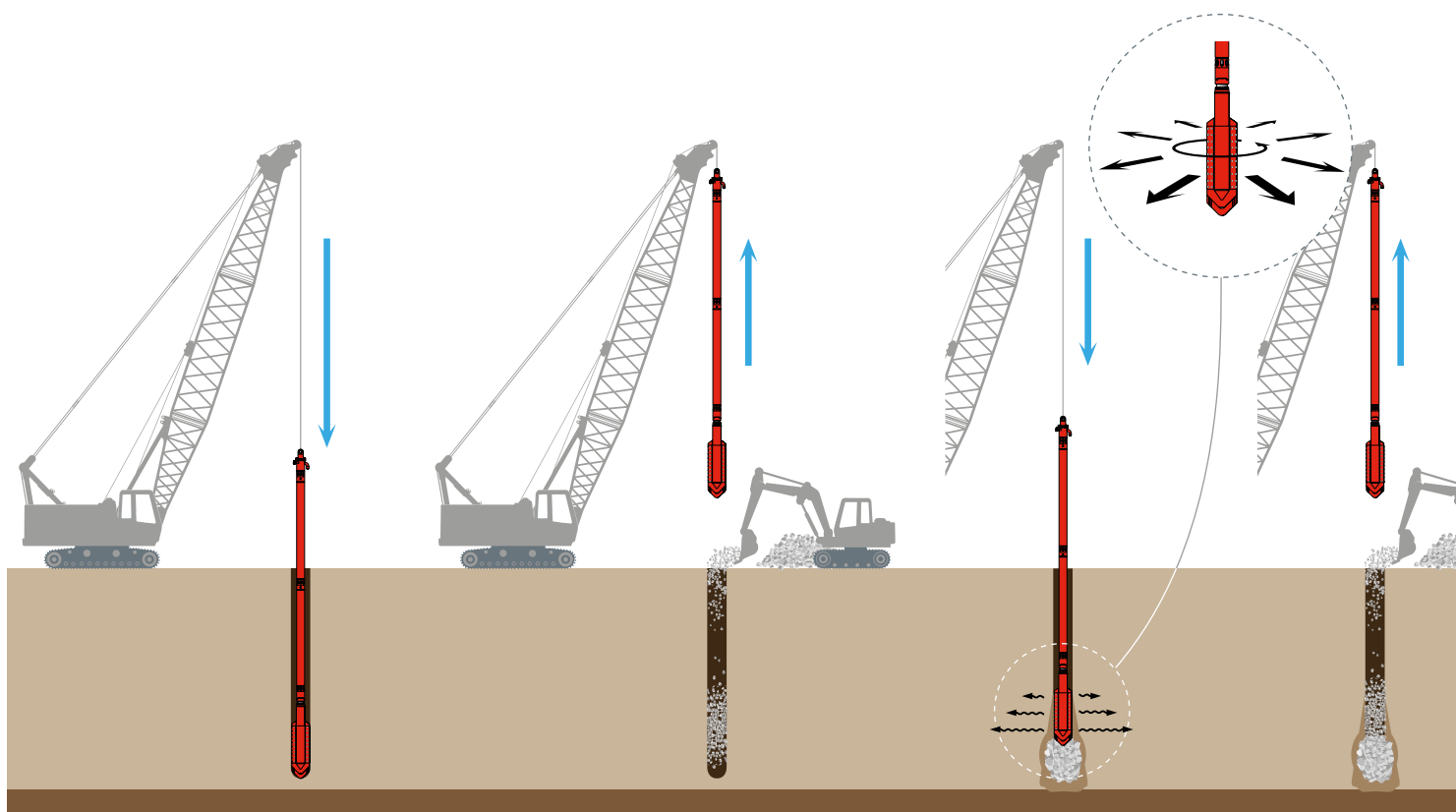

### 1. Penetration

The PTC Vibrolance penetrates the ground to form the hole that will contain the stone column. The Vibrolance penetration force is the result of the combined effect of the vibrations emitted by the Vibrator and the Vibrolance own weight.

The penetration can be assisted by air or water jetting at the tip of the Vibrolance.

### 2. Stone feeding

When the required depth is reached, the Vibrolance is withdrawn to surface level. Stones (coarse gravel, crushed stone or crushed aggregate) are placed into the hole from the ground surface with an excavator.

### 3. Compaction

The Vibrolance is reinserted in the hole to perform the compaction of the stores.

The vibrations of the Vibrolance compact the stones, by forcing out the stones and interlocking them with the in-situ soil. When the required degree of compaction has been reached, the Vibrolance is withdrawn again to the surface level.

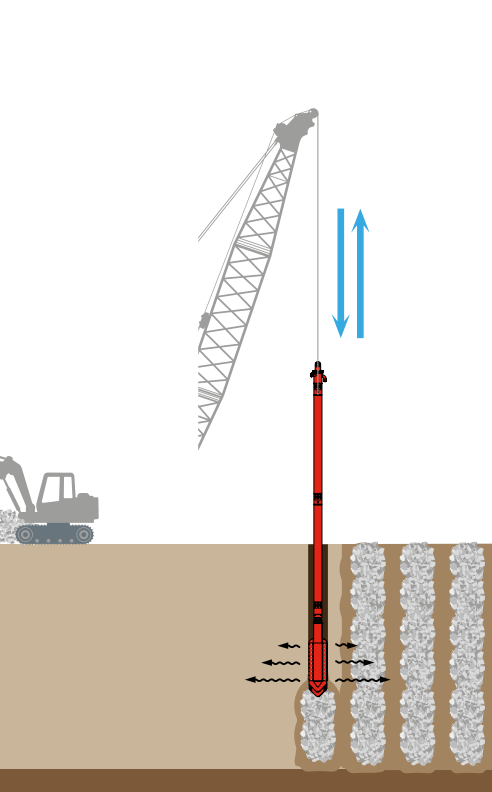

#### 4. Finishing

The stone feeding and compacting cycles are repeated until a column of very compact stone interlocked with the surrounding ground is built up to ground level. The Vibrolance is repositioned at the next spot of the grid to start a new column.

### OFFSHORE

Top Feed stone columns can be installed under water. For this application the most commonly used method is to install a blanket of gravel on the seabed. Afterwards, the Vibrolance® penetrates the water, the gravel blanket and finally the seabed at desired depth. The gravel on the seabed is pushed down to the hole created by the Vibrolance, and forms a stone column.

# STONE COLUMNS

Top feed method.

## EQUIPMENT: VIBROLANCE VL18 - VL40 - VL40S

PTC Vibrolance models can be used on vibro compaction as much as stones columns. The system 2 in 1 offers to its customer the most economical and adapted products on both solutions.



### AVAILABLE VERSION

CRANE  
SUSPENDED  
VL-F



EXCAVATOR  
MOUNTED  
VL-E



RIG  
MOUNTED  
VL-R



VIBROLANCE®		VL18	VL40	VL40S
ECCENTRIC MOMENT	m.kg	1.8	4.0	4.0
VIBROLANCE POWER	kW/HP	113 / 154	135 / 183	180 / 245
FREQUENCY	Hz/rpm	50 / 3000	30 / 1800	40 / 2400
CENTRIFUGAL FORCE	kN	181	145	258
WATER JETTING SYSTEM		Option	Option	Option
AIR JETTING SYSTEM		Option	Option	Option
<b>RECOMMENDED POWER PACK</b>				
MODEL		240	240	400

*PTC reserves the right to modify the technical data without notice.*

## APPLICATIONS

- Increase of soil bearing capacity.
- Improve the settlement characteristics of the ground.
- Speed up of vertical drainage.
- Stability of embankments.
- Reduction of the soil liquefaction risk in seismic areas.
- Offshore top-feed stone columns.



Two Vibrolances doing top feed stone columns under water at 17 m depth for the Malabo Harbor, **Equatorial Guinea**.



900 stone columns realized with a VL18 Vibrolance for the foundation of a new school in Sharjah, UAE. Those column was installed with a triangular grid of 2.5m, 4m deep within 3 weeks.



Two Vibrolances VL40S sets for the construction of a new hospital in Quebec, Canada. The project consists of working on the soil treatment by installing 12 000 linear meters of stone columns. Each Vibrolance had a productivity of 150 linear meters a day.



2030 stone columns of 8 m depth have been built by two Vibrolances VL18 for the ground treatment of an industrial area, **India**.

# STONE COLUMNS

## Bottom feed method.

The stone columns are a vibro replacement technique recommended for granular soils with high fines content, soft cohesive saturated soils and mixed fills. This technique consists in building and compacting in the ground load bearing columns made from gravel or crushed stone.

The Bottom feed method, is used to produce high quality stone columns due to the fact that the stones are fed directly at the bottom of the hole created by the Vibrolance®, up to the surface. This is possible thanks to a stone feeding tube at the tip of the Vibrolance. The pull-down force of the carrier, the mast verticality and the monitoring system, offer additional advantages to make this method the most reliable and productive for stone columns in small and large projects.

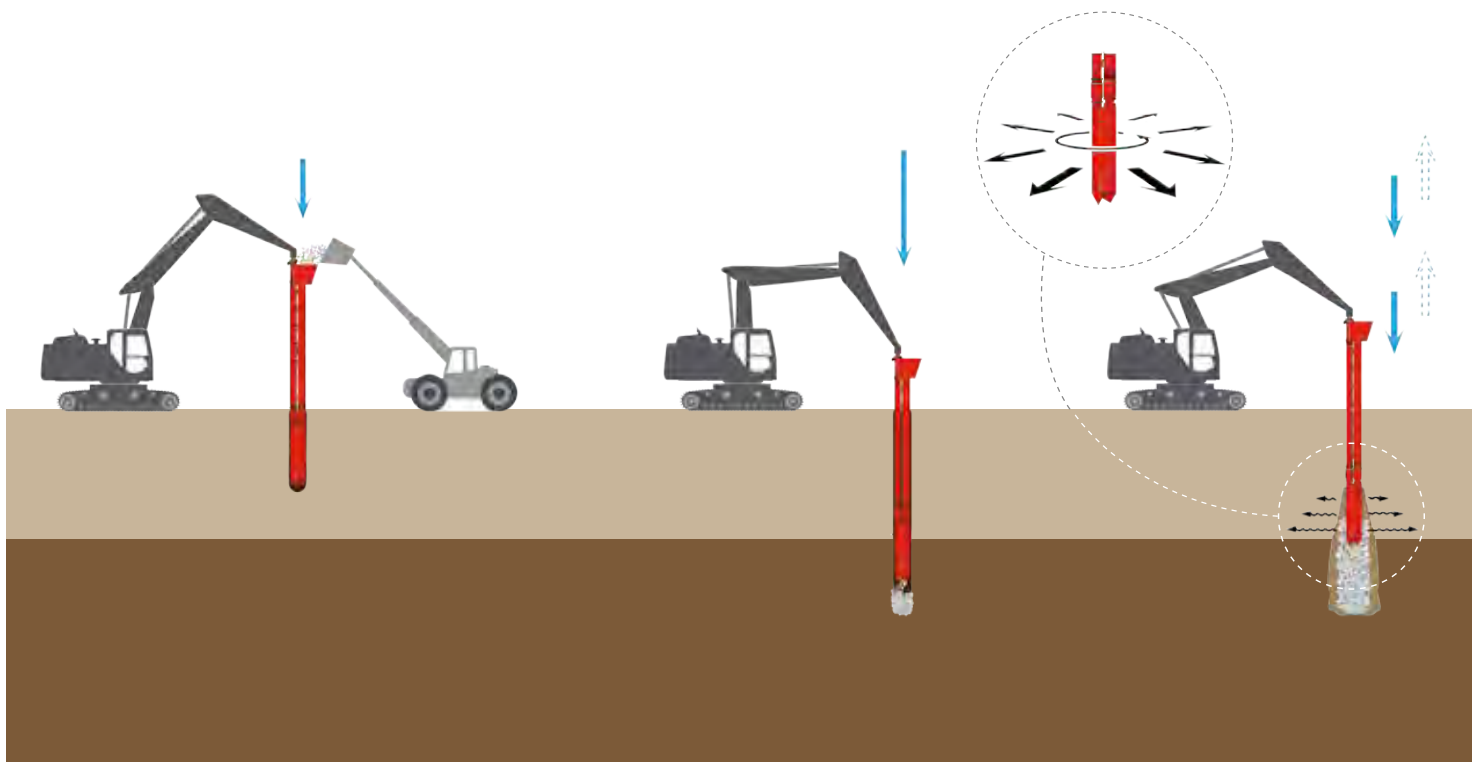

### 1. Preparation

The hopper at the top of the Vibrolance is filled with stones. The Vibrolance penetrates into the soil.

### 2. Penetration

When the required depth of treatment is attained, the stones are poured into the space created by the Vibrolance.

### 3. Stone feeding

The Vibrolance rises up a few centimeters, adds stones and then drops down to compact them.



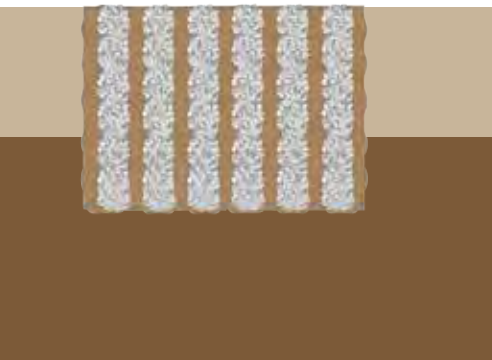

#### 4. Compaction

The Vibrolance performs several compaction cycles until it reaches ground level.

#### OFFSHORE

Stone columns using the bottom feed method can also be build in the seabed. A free hanging Vibrolance® (BFS) equipped with a stone tube and a stone tank is required.

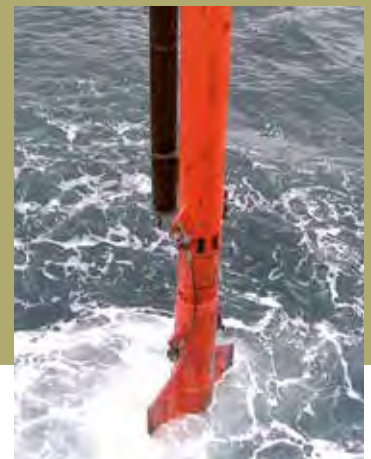

# STONE COLUMNS

## Bottom feed method.

### EQUIPMENT: VIBROLANCE BFS18 - F/E/R - BFS40 - F/E/R

PTC Vibrolance models with Bottom Feed system offer a variety of working possibilities (Rig, Crane, Excavator) for the production of stone columns.

F : Free Hanging

E : Excavator Mounted

R : Rig Mounted



### AVAILABLE VERSION

CRANE  
SUSPENDED  
F



EXCAVATOR  
MOUNTED  
E



RIG  
MOUNTED  
R



\*Adaptation required, depending on the type of rig. Please consult PTC.

VIBROLANCE®		BFS18 (E/R)	BFS40 (E/R)
SOIL TREATMENT DEPTH (in standard configuration)	m	6	18
MAX. SOIL TREATMENT DEPTH (with extensions)	m	17.5	23
STONE COLUMN DIAMETER	mm	450 - 800	650 - 1200
HYDRAULIC POWER	kW/HP	113 / 154	180 / 245
HYDRAULIC FLOW	l/min	190	300
OPERATIONAL FREQUENCY	Hz/rpm	50 / 3000	40 / 2400
CENTRIFUGAL FORCE	kN	181	258
ECCENTRIC MOMENT	m.kg	1.8	4.1
AIR JETTING SYSTEM		Option	Option
<b>RECOMMENDED POWER PACK</b>			
MODEL		240	400



PTC reserves the right to modify the technical data without notice.

## CONTINUOUS PRODUCTION: HIGH PRODUCTIVITY

### Easy loading of the skip:

The very low height of the skip permits to easily charge the stones with broadly available loaders.

**No interruptions for stone feeding, thanks to the high capacity of the skip and the stone tank.**

## QUALITY OF THE STONE COLUMN

The use of the Vibcorder® monitoring and recording system, allows to monitor in real time: the length, diameter, and verticality of the stone column. These parameters can be registered for analysis and to guarantee to the client the quality of the ground improvement job.

## APPLICATIONS

- Increase of soil bearing capacity.
- Decrease in soil settlement under load.
- Speed up of vertical drainage.
- Stability of embankments.
- Reduction of the soil liquefaction risk in seismic areas.
- Offshore Bottom-feed stone columns.



# COMPLEMENTARY EQUIPMENT

## POWER PACKS

Power pack models complying to the most recent environmental regulations and emission standards. These power packs are equipped with Ecomode, which is an electronic module that reduces fuel consumption, polluting emissions and noise. This module automatically adapts the speed of the diesel engine to only supply the power that is needed according to the soil conditions.



POWER PACKS		240VO	400CO	400VO
OPEN LOOP CIRCUIT		OPEN LOOP	OPEN LOOP	OPEN LOOP
ENGINE MODEL (STAGE V)		VOLVO TAD 582 VE	-	VOLVO TAD 883 VE
ENGINE MODEL (STAGE IV)		VOLVO TAD 572 VE	-	VOLVO TAD 873 VE
ENGINE MODEL (STAGE IIIA)		VOLVO TAD 552 VE	CAT C9	VOLVO TAD 853 VE
ENGINE MODEL (STAGE II)		-	-	-
ENGINE POWER	kW/HP	160 / 217	242 / 329	235 / 319
ROTATION SPEED	rpm	2200	2200	2200
MAX. OIL FLOW	L/min	280	500	500
NOMINAL OIL FLOW	L/min	240	380	380
MAX. PRESSURE	bar	350	350	350
HYDRAULIC OIL CAPACITY	L	710	700	710
FUEL CAPACITY	L	595	650	595
LENGTH	m	3.50	3.85	3.50
WIDTH	m	1.60	1.60	1.60
HEIGHT	m	2.15	2.02	2.15
WEIGHT (with fuel)	kg	3975	5585	5100
ECOMODE*		ECOMODE	ECOMODE	ECOMODE
QUICK COUPLINGS		STANDARD	STANDARD	STANDARD
CONNECTING HOSES	m	30	30	30
CONNECTING HOSES	kg	220	350	350

*PTC reserves the right to modify the technical data without notice.*

# OPTIONAL EQUIPMENT: AIR & WATER JETTING

Air or water jetting are frequently used to assist the Vibrolance penetration in the ground. Their use will depend on the treatment depth and the type of ground improvement technique being applied. When the soil treatment is done at important depths (generally more than 20 m), side water jetting is recommended to assist the extraction of the Vibrolance. Please consult PTC for advise on the type of jetting system that is best adapted to your application.

## Air compressor



## Water jetting pumps

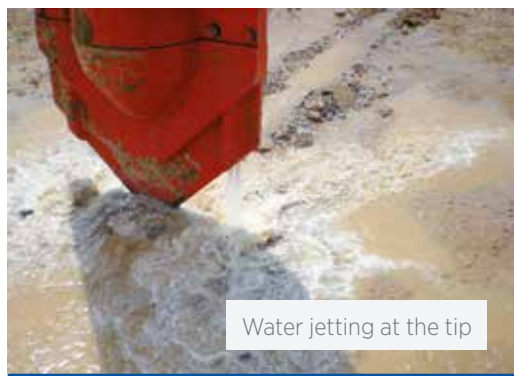

Water jetting at the tip

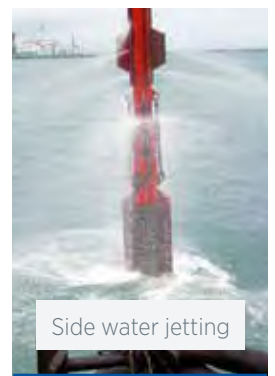

Side water jetting

AIR COMPRESSOR		KAESER M114	KAESER M122
ENGINE MODEL		DEUTZ	DEUTZ
MAX. WORKING PRESSURE	Bar	10	10
AIR FLOW	m <sup>3</sup> /min	9.7	9.5

*PTC reserves the right to modify the technical data without notice.*

WATER JETTING PUMP		WJ70	WJ150
OPERATIONAL WATER FLOW/PRESSURE	m <sup>3</sup> /h	70 (at 15.5 bar)	150 (at 15.5 bar)
MAXIMUM WATER PRESSURE	Bar	16	16

*PTC reserves the right to modify the technical data without notice.*

# VIBCORDER®

## Monitoring system.

The Vibcorder® is the monitoring system recommended for all PTC Vibrolances and stone column rigs. It monitors in real time a variety of working parameters allowing to be sure to comply with the job site requirements.

The Vibcorder® displays in real time the following measurements:

- Soil compaction, through the reading of the Vibrolance pressure.
- Depth of the Vibrolance (in meters).

### Optional Vibcorder® parameters:

- Stone consumption (cubic meters) and stone column profile (diameter of the stone column depending of the depth).
- Verticality of the Vibrolance (through the use of the inclinometer).
- Position of the Vibrolance (with the use of a GPS system). This parameter is especially useful for offshore projects where following a precise grid is needed.

In addition, you can get a copy of the data on a USB key or store the data on your computer, to analyse the work data and prepare better for the next jobsite or to show it to a certification body.

Data can be also transmitted directly by mobile network (additional subscription required with your mobile operator) and be analysed instantly at your headquarter.

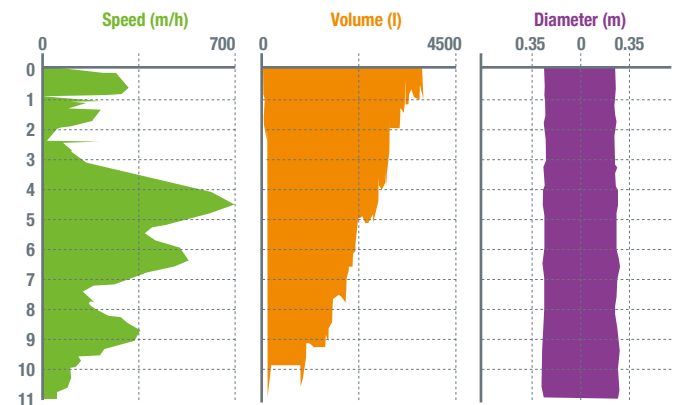

### DEPTH

It can be obtained through the use of one of the following sensors:



Displacement sensor:  
to be set  
on the winch



Hydrostatic sensor:  
set directly  
on the equipment



### VERTICALITY

Measured with an inclinometer.

### GPS POSITIONING

Position of the Vibrolance.



### STONE COLUMN DIAMETER

Stone consumption sensor measures gravel consumption and gives the stone column profile.

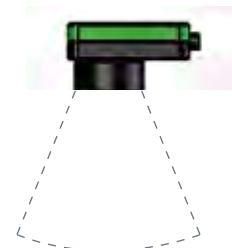

# YOU ARE THE CONTRACTOR

PTC ground improvement equipment opens a window of new market opportunities for contractors.



## MORE AUTONOMY AND CONTROL

- You do the job, it is your equipment.
- You control every aspect of the jobsite.
- No hidden costs.
- No more outsourcing.

## SIMPLE AND COST-EFFECTIVE

- The simplicity of the vibrolance modular design and assembly, results in great reliability and ease of on-site maintenance
- Easy to operate: With a short training your personnel can operate it.
- Low equipment investment:  
You can use the Vibrolances with your regular crane or rig.



*Our technical support and wide variety of ground improvement equipment gives you the opportunity to carry out high quality vibro compaction and stone column jobs. We provide the solution... you are in charge of the job.*

# WORLDWIDE NETWORK IN OVER 40 COUNTRIES



[www.ptc.fayat.com](http://www.ptc.fayat.com)

## PTC Headquarter

56 rue de Neuilly  
93136 Noisy-le-Sec Cedex France  
Tel: **+33 1 49 42 72 95**  
Mail: [contact@ptc.fayat.com](mailto:contact@ptc.fayat.com)

## PTC MIDDLE EAST

JAFZA south FZS1 AH03  
P.O. Box 262637, Jebel Ali-Dubai - UA  
Tel: **+971 4-8863233**  
Mob: **+971 50 340 2451**  
Mail: [s.espin@ptc.fayat.com](mailto:s.espin@ptc.fayat.com)

## PTC FAR EAST

3 Tuas Avenue 16  
638926 - Singapore  
Tel: **+65 6861 7977**  
Tel: **+65 6861 6338**  
Mail: [ptcfe@ptcfareast.com](mailto:ptcfe@ptcfareast.com)

## DOWNLOAD OUR NEW MOBILE APP :

IOS



ANDROID

