

FOUNDATION EQUIPMENT

# THE RANGE \_\_\_\_\_ \_\_\_\_\_ OF OUR PRODUCTS \_\_\_\_\_



/01

# THE \_\_\_\_\_ \_HYDRAULIC PILING RIGS\_



- **LONG LIFE EQUIPMENT**
- **EFFICIENCY AND CONTROL**
- **RELIABILITY AND PERFORMANCE**
- **VERSATILITY**
- **SAFETY**

Casagrande is a world leader supplier of foundation equipment. The piling rigs are designed to satisfy most of the necessities to execute modern foundation technologies. Supplying the right equipment and services to enable the contractor to achieve the best results on site is our object. The main design specifications of our high quality piling rigs do consider safety standards, reliability, performances, duration and resale value.



# EQUIPMENT RANGE

# XP-2

Casagrande provides a wide range of **high-performance equipment**, XP-2 advanced technology and operation competitiveness. From 30 T to 170 T for all kinds of foundation engineering jobs.

## Bored Piles



Piling Rigs XP-2 series	B125	B160	B175	B200	B250
Max diameter - mm	1500	1500	1500	1800	2000
Max depth - m	50	50	57	68	78
Max diameter CFA - mm	900	900	900	1000	1200
Max depth CFA - m	22,6	22,6	26	28	29
Rotary head torque - kNm	135	160	175	210	263
Engine power - kW	186	186	209	246	336
Weight - t	39	41	42	65	83

The Range Of Our Products

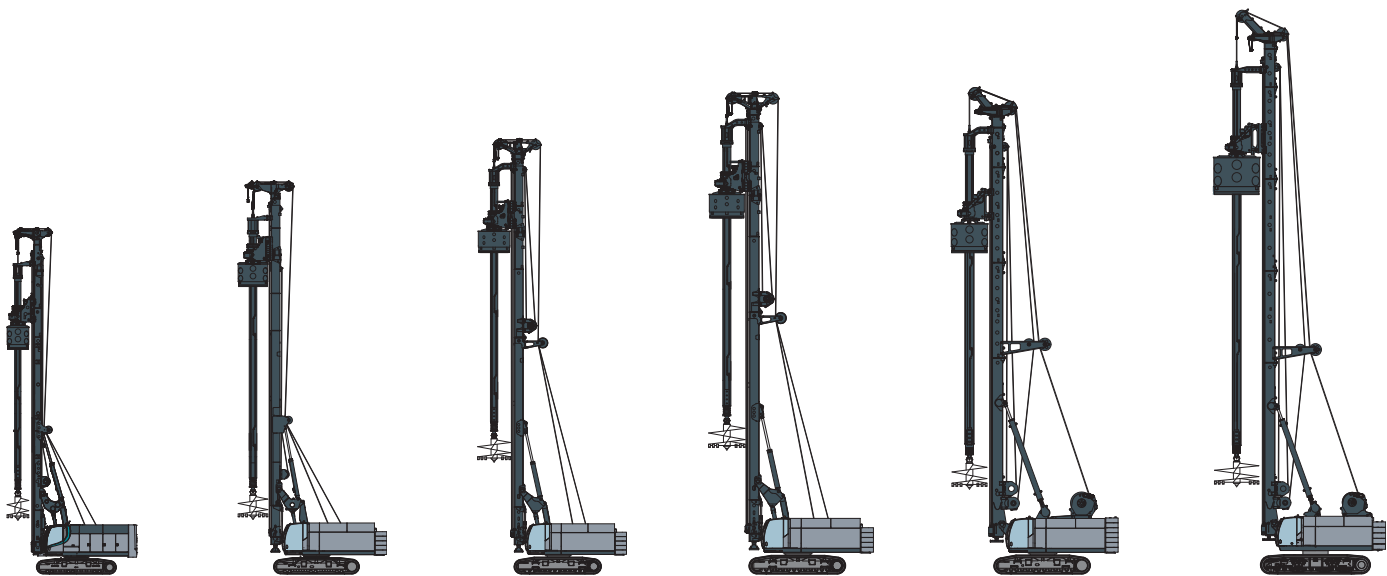

B275	B300	B360	B400	B420	B470
2000	2200	2700	2700	2700	3500
78	89	101	101	101	111
1200	1200	1200	1200	1200	1500
29	29	34	34	35	40
300	300	400	470	470	470
336	400	400	450	450	450/620
90	102	125	128	140	167

# CASAGRANDE CLASSIC LINE

The Casagrande **Classic Rigs**, designed from the tradition to give the specialist contractors an equipment performing foundation techniques in the geotechnical engineering such as bored piles, continuous flight auger and eventually diaphragm wall.

Comfortable cabin and simplified interface keeps the operator efficient and ready for high productivity.



The **hydraulic circuit** and the controls of the machine are based on traditional electro-hydraulic logic elements in order to be as easy as possible. The ideal operating weight allows easy transport and fast set up.

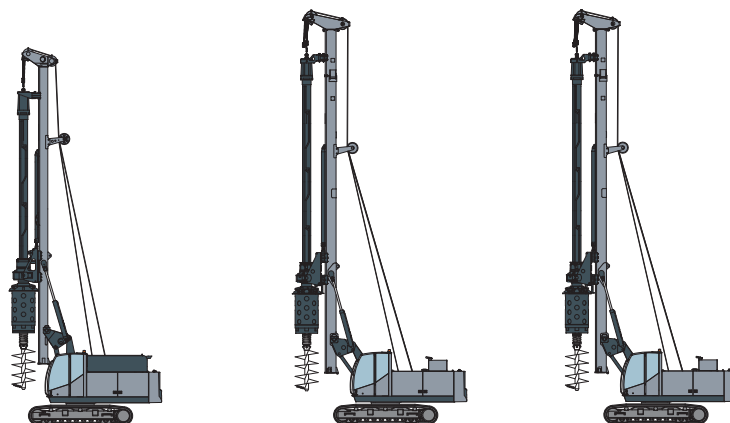

Piling Rigs C-Series	C30	C35	C40
Max diameter - mm	1200	1500	1500
Max depth - m	42	50	50
Max diameter CFA - mm	800	800	800
Max depth CFA - m	20	22,6	22,6
Rotary head torque - kNm	125	135	177
Engine power - kW	164	164	194
Weight - t	35	39	42



/02

# DIAPHRAGM WALL EQUIPMENT





➤ **FD HYDROMILLS**

➤ **KRC KELLY GUIDED GRABS**

➤ **ROPE SUSPENDED HYDRAULIC GRABS**

Casagrande started manufacturing equipment for diaphragm walls in 1963. Over the years, it has developed a complete range of machines in order to satisfy all the contractor's requirements from kelly guided grabs to rope suspended grabs.

Whenever the difficult soil condition or high productivity and shear accuracy are required the Casagrande Hydromill is a must.



# EQUIPMENT RANGE



## FD hydromills

Model	FD60	FD100
Max Depth - m	64	100
Width of Trench - mm	700 ÷ 1200	800 ÷ 1500
Length of Trench - mm	3150	3150
Engine Power - kW	480	480
Weight - t	154	163

## KRC Kelly Guided Grabs

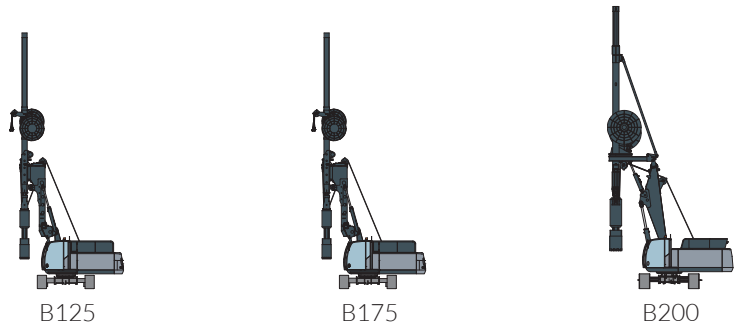

Model	KRC1	KRC1	KRC2
Max Depth - m	30	30	35
Width of Trench - mm	400 ÷ 800	400 ÷ 800	500 ÷ 1500
Length of Trench - mm	2200 ÷ 2500	2200 ÷ 2500	2200 ÷ 3000
Engine Power - kW	186	209	246
Weight - t	41	42	62

## Rope Suspended Hydraulic Grabs

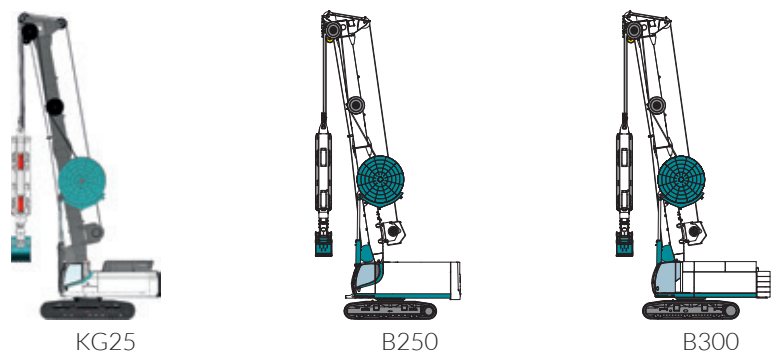

Model	KHD25	KHD25	KHD28
Max Depth - m	80	80	80
Width of Trench - mm	600 ÷ 1500	600 ÷ 1500	600 ÷ 1500
Length of Trench - mm	2500 ÷ 3200	2500 ÷ 3200	2500 ÷ 3200
Engine Power - kW	246	336	400
Weight - t	~85	~90	~97

The Range Of Our Products

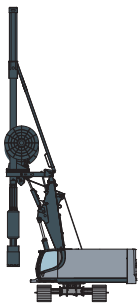

B250

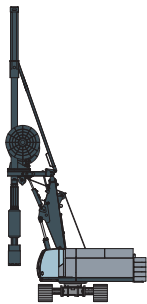

B300

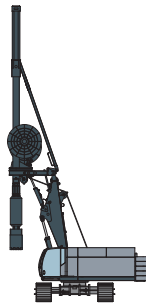

B360

KRC2HD	KRC2HD	KRC2HD
35	46	46
500 ÷ 1500	500 ÷ 1500	500 ÷ 1500
2200 ÷ 3000	2200 ÷ 3000	2200 ÷ 3000
336	400	400
78	85	100

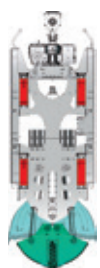

HYDRAULIC GRAB

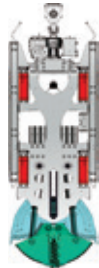

HYDRAULIC GRAB



MECHANICAL GRAB

KHD25	KHD28	PM
-	-	-
600 ÷ 1500	600 ÷ 1500	600 ÷ 1500
2500 ÷ 3000	2800 ÷ 4000	2500 ÷ 3200
-	-	-
12 ÷ 25	16 ÷ 30	10 ÷ 20

/03

# THE \_\_\_\_\_ \_\_\_\_\_ HYDRAULIC DRILLING RIGS \_\_\_\_\_



➤ **LONG LIFE EQUIPMENT**

➤ **VERSATILITY**

➤ **RELIABILITY AND PERFORMANCE**

➤ **SAFETY**

Casagrande expertise manufacturing crawler drills provide answers to all contractor's needs in jobs such as micropiles, anchors, tie-backs, grouting and jet grouting. All the equipment can be customized as well as installed with all the latest safety systems required. Extensive accessories such as rod loaders, pumps and drilling tools can be supplied.



# EQUIPMENT \_\_\_\_\_ \_\_\_\_\_ RANGE

# XP-2

Casagrande provides a wide range of **high-performance drilling rigs** equipment, advanced technology and operation competitiveness.

From 6 T to 40 T satisfying all needs in geotechnical applications.



Drilling Rigs XP-2 series	C3	C5R	C5	C6	C7
Engine power - kW	100	97	97	119	168
Torque - kNm	15,2	17	15,2	20	30
Stroke - Single rotary head - m	3,2	4	3,6	7,1	10
Extraction/Crowd force - kN	50	50	50	85	86,5
Weight - t	6,5	7,9 + 2,1	9	15	22
Jet-grouting depth in single passage - mm	7	-	12	19	26

The Range Of Our Products



C8	C9	C10	C12	C16
209	209	209	209	209
30	55	55	55	55
10	10	10	13	16
86,5	150	150	150	150
24	27	28	30	37
28	26	28	30,5	36

# JET \_\_\_\_\_ \_\_\_\_ GROUTING EQUIPMENT \_\_\_\_\_

➤ HIGH PRESSURE PUMPS

➤ MIXING PLANT

➤ DRILL STRING





The Range Of Our Products



# MULTI FUNCTION RIG



V16-19

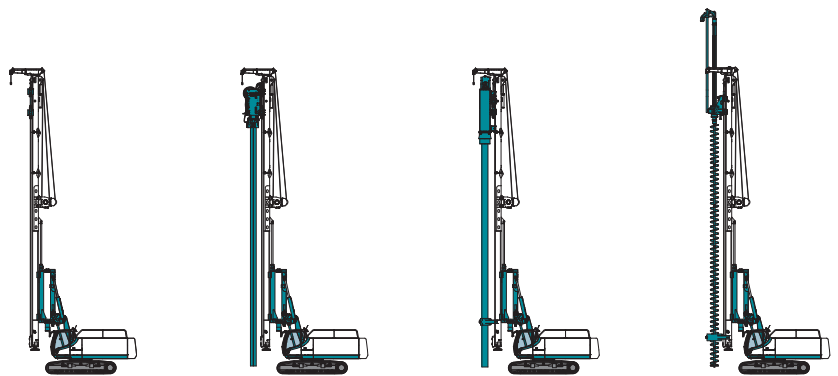

Model	BASE CARRIER	VIBRATOR FOR SHEET PILES	PILE DRIVING WITH HYDRAULIC HAMMER	CFA CONTINUOUS FLIGHT AUGER
Diesel engine - kW	470	-	-	-
Max pile length - m	-	19,7	19,7	-
Max depth - m	-	-	-	25,7
Max diameter - mm	-	-	-	600
Weight - t	60	65	73	68

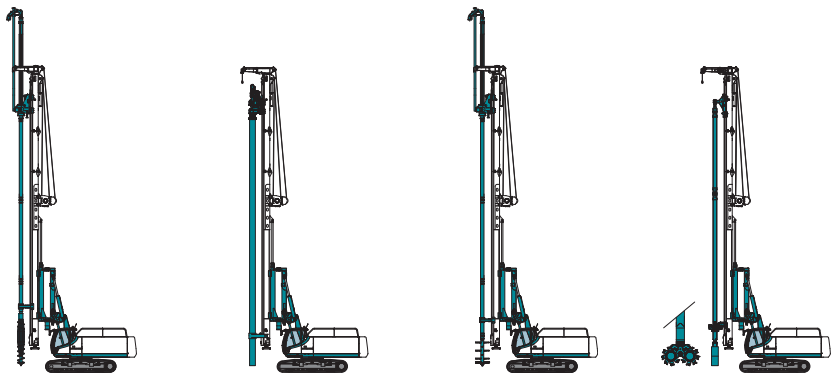

Model	DISPLACEMENT PILES	CASED CFA VdW	SOIL MIXING	CUTTING SOIL MIXING
Max depth - m	25,7	19,7	25,7	19
Max diameter - mm	-	500	1200	-
Trench - mm	-	-	-	1000 x 2800
Weight - t	68	68	68	72

# FOUNDATION DRILLING TOOLS AND ACCESSORIES

In order to obtain the best of the innovated hydraulic installed on the machine and transfer properly to the ground, we have created a new and complete range of drilling tools and accessories.

Buckets



Augers



Core Barrels

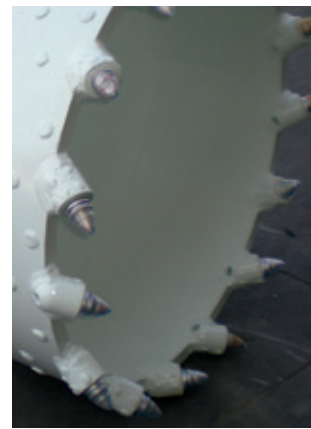

Special Tools

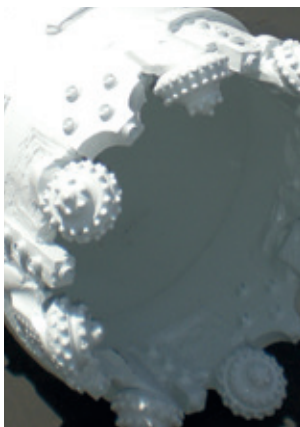

FDP



Tools Spare Parts





**Casagrande S.p.A.**  
Via Malignani, 1  
33074 Fontanafredda  
Pordenone (Italy)

T. +39 0434 9941  
F. +39 0434 997009

[info@casagrandegroup.com](mailto:info@casagrandegroup.com)  
[www.casagrandegroup.com](http://www.casagrandegroup.com)